



*An Online CPD Course
brought to you by
CEDengineering.ca*

Introduction to Fuel Cells

Course No: R07-001

Credit: 7 PDH

Anuj Bhatia

CED CANADA
engineering.ca
CPD FOR THE PROFESSIONAL

Continuing Education and Development, Inc.

P: (877) 322-5800

info@cedengineering.ca

www.cedengineering.ca

TABLE OF CONTENTS

1 CHAPTER -1: FUEL CELLS 4

1.1 Introduction 4

1.2 Components of a Fuel Cell..... 4

1.3 Working of Fuel Cell..... 5

1.4 Need for Fuel Cells 6

1.5 Advantages of Fuel Cells 7

1.6 Disadvantages of Fuel Cells..... 11

1.7 Comparison of Fuel Cells with Batteries 14

1.8 Comparison of Fuel Cells with Heat Engines 14

1.9 Key Features of Fuel Cells 16

2 CHAPTER -2: APPLICATIONS OF FUEL CELLS 19

2.1 Transportation 19

2.2 Stationary Power 21

2.3 Portable Power Systems 23

2.4 Combined Heat and Power (CHP) Applications..... 25

2.5 Other Applications 26

3 CHAPTER -3: TECHNOLOGY DESCRIPTION 27

3.1 Hydrogen Fuel Cells..... 27

3.1 Fuel Cell Stack 29

3.3 Fuel Cell Types & Construction..... 31

3.4 Fuel Cell Subsystems 32

3.5 Balance of Plant (BOP) 35

4 CHAPTER - 4: TYPES OF FUEL CELLS 38

4.1 Classification of Fuel Cells 38

4.2 Fuel Cell Types 40

5 CHAPTER - 5: PROTON EXCHANGE MEMBRANE FUEL CELLS 44

5.1 Main Components of PEMFC..... 45

5.2 Materials of PEMFC 46

5.3 Factors Affecting the Performance of Hydrogen Fuel Cell 50

5.4 PEMFC Advantages and Disadvantages..... 54

6	CHAPTER – 6: PHOSPHORIC ACID FUEL CELL (PAFC).....	55
6.1	Characteristics	55
6.2	PAFC Structure	56
6.3	Advantages and Disadvantages	57
7	CHAPTER - 7: MOLTEN CARBONATE FUEL CELLS (MCFC)	59
7.2	Structure of MCFC.....	60
7.3	Advantages and Disadvantages	61
8	CHAPTER - 8: SOLID OXIDE FUEL CELLS (SOFC)	63
8.1	Solid Oxide Fuel Cells Structure.....	63
8.2	Design Configurations.....	64
8.3	Advantages and Disadvantages	66
9	CHAPTER - 9: DIRECT METHANOL FUEL CELLS (DMFC)	68
9.1	DMFC Structure	68
9.2	Advantages and Disadvantages	70
10	CHAPTER - 10: ALKALINE FUEL CELLS (AFC).....	71
10.1	Type of Electrolytes	71
10.2	Alkaline Fuel Cells Structure	72
10.3	Advantages and Disadvantages	73
11	CHAPTER -11: SUMMARY COMPARISON OF FUEL CELLS	75
11.1	Characteristics of Different Fuel Cells.....	75
11.2	Key Suppliers	79
12	CHAPTER - 12: COST ECONOMICS OF FUEL CELLS	81
12.1	Capital Cost	81
12.2	Fuel Costs.....	83
12.3	Maintenance Costs	83

TABLE OF FIGURES AND TABLES

Figure 1.	Galvanic Cell Operation	6
Figure 2.	Conventional methods of generating power.....	8
Figure 3.	Fuel-cell-package methods of generating power.....	8
Figure 4.	Hydrogen Generation, Storage, Distribution & Applications	12
Figure 5.	Efficiency Characteristics.....	16
Figure 6.	Fuel Cell Vehicle.....	20
Figure 7.	Fuel cell vehicles	21

Figure 8.Fuel Cells for Power Generation & Storage.....	22
Figure 9.Stationary power fuel cells	23
Figure 10.Portable fuel cell applications	24
Figure 11.Fuel Cells in CHP Applications	26
Figure 12.Generic Hydrogen Fuel Cell Operation.....	28
Figure 13.PEMFC Cell Stack	30
Figure 14.Fuel cell power plant	32
Figure 15.Heat and Power Flows within Fuel Cell System.....	34
Figure 16.Fuel Cell Module.....	38
Figure 17.Basic Principle of PEMFC	44
Figure 18.Structure of PEMFC.....	46
Figure 19.PEM Flow Field Plates.....	49
Figure 20. PEM Membrane Electrode Assemblies.....	50
Figure 21.Typical I-V Curve for PEM Fuel Cell.....	51
Figure 22.PAFC Structure	56
Figure 23.Basic Principle of MCFCs.....	59
Figure 24.SOFC Structure	64
Figure 25.Cross-section of the Tubular Design	65
Figure 26.Planar Cell Design.....	66
Figure 27.DMFC Structure	69
Figure 28. AFC Structure.....	72
Figure 29.Fuel Cell Types for Different Applications.....	79
Figure 30.Industry Leaders for Fuel Cells	80
Figure 31.Annual Production.....	82
Table 1.Emissions profile of a fuel cell versus other forms of distributed and central power generation.....	9
Table 2.Effect of Temperature on Parameters	53
Table 3. Characteristics of Different Fuel Cells	76
Table 4.Advantages and Disadvantages of Different Fuel Cell Types.....	77
Table 5.Different Fuel Cells Applications	78

1 CHAPTER -1: FUEL CELLS

1.1 Introduction

A fuel cell is an electrochemical device that generates electrical energy from fuel via an electrochemical reaction. The process is reverse of water electrolysis in which electric current breaks down water into hydrogen and oxygen ions. In fuel cells, hydrogen (fuel) and oxidizer (oxygen or air) react chemically to generate electricity, heat, and water.

Fuel + oxidant → electricity + heat + water

In many ways, the fuel cell is analogous to a battery. The key difference between batteries and fuel cells is that while batteries store energy, fuel cells produce electricity continuously if fuels are supplied.

The first commercial usage of fuel cells was in the 1960s when NASA utilized them to power satellites and space shuttles. Fuel cells have since been used in many applications ranging from portable gadgets, automobiles, and stationary power generation.

1.2 Components of a Fuel Cell

The working of fuel cells is simple. It contains three main components:

- a. Anode
- b. Cathode
- c. Electrolyte

1.2.1 Anode

The anode is the negative post of the fuel cell. It is the electrode where oxidation takes place. It conducts the electrons that are freed from the hydrogen molecules so that they can be used in an external circuit. It has channels attached to it that disperse the hydrogen equally over the surface of the catalyst.

1.2.2 Cathode

The cathode is the positive post of the fuel cell. It has channels etched into it that distribute the oxygen to the surface of the catalyst. It also conducts the electrons back from the external circuit to the catalyst, where they can recombine with the hydrogen ions and oxygen to form water.

Both anode and cathode are made from a thin carbon fiber paper which allows the active gases to pass through and the electrode surfaces support platinum catalysts. Carbon fiber paper is commonly used because it is porous, hydrophobic (non-wettable), conductive, and non-corrosive. The material is very thin to maximize gas and water transport.

1.2.3 Catalyst

Catalyst is a chemical substance that increases the rate of reaction. The catalyst is a special material that facilitates the reaction of oxygen and hydrogen. It is usually made of platinum powder very thinly coated onto carbon paper or cloth. The catalyst is rough and porous so that the maximum surface area of the platinum can be exposed to hydrogen or oxygen.

Platinum is very expensive, so the amount used (known as the catalyst loading) is a significant factor in the cost of a fuel cell. Fuel cell designers strive to minimize the amount of platinum used while maintaining good cell performance.

1.2.4 Electrolyte

The electrolyte is a substance that conducts charged ions from one electrode to the other in a fuel cell. This is a specially treated material that only conducts positively charged ions.

1.3 Working of Fuel Cell

Fuel cells work much like batteries. A chemical reaction takes place between the electrodes (anode and cathode) and the movement of charged hydrogen ions across an electrolyte membrane generates a current.

The schematic diagram of the fuel cell is provided below.

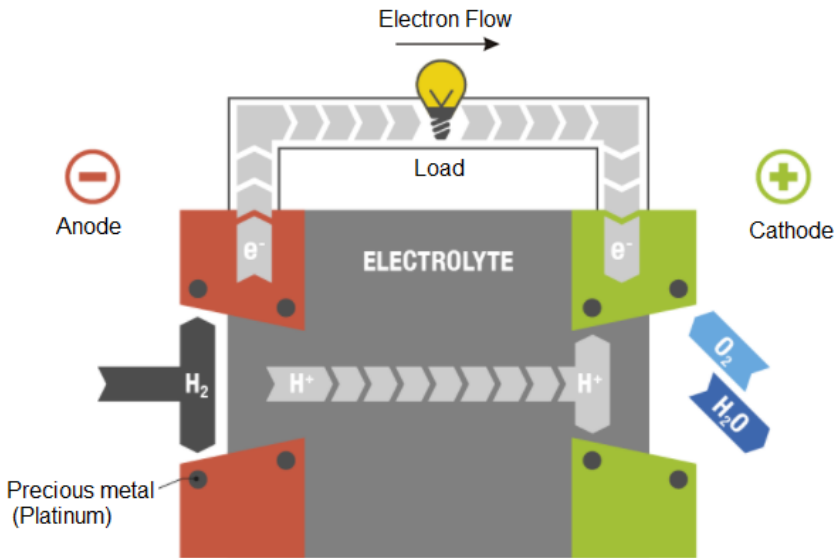

Figure 1. Galvanic Cell Operation

The electrodes are coated with a platinum or palladium catalyst and separated from each other by an electrolyte. Without the catalyst, hydrogen and oxygen would not react to produce heat and electricity. The electrolyte consists of an ion-conducting membrane, and this membrane needs to be permeable for protons and impermeable to electrons.

1.4 Need for Fuel Cells

The primary reason for the adoption of fuel cells is the increasing reliance and dependency on the use of fossil fuels, which has led to global warming and extreme weather patterns. Aside from the pollution and environmental issues, the use of fossil fuels such as oil has grown to the point where the sources of production have become scarce. As a result, more challenging expeditions for oil reserves will be required, which may result in a very high oil price.

Fuel cells are undoubtedly an option to the above-mentioned concerns. They are a clear answer to end fossil fuel dependence. The finest characteristic of fuel cells is that pure water is produced as a by-product. As a result, they are free of pollution. The technology will undoubtedly solve the rising oil issues.

1.4.1 Fuels & Oxidant

Hydrogen is the best fuel for fuel cells since it is more electrochemically reactive than other fuels like hydrocarbons (natural gas or LPG) or alcohols.

Fuel cells can also run on various hydrocarbon gases. After cleaning (removing sulfur and other contaminants), the fuel must be converted into a hydrogen-rich 'reformate' before being fed into the fuel cell stack.

- a. High-temperature fuel cells typically run on hydrocarbon fuels, notably hydrogen-rich gases like methane.
- b. Low-temperature systems can run on methanol.

The most used oxidants are oxygen, chlorine, and chlorine dioxide.

1.4.1.1 Facts about Hydrogen

- a. Hydrogen is the perfect environmentally friendly fuel for fuel cells for stationary power generation. It can also be used as the fuel in internal combustion engines to replace petrol or diesel.
- b. Hydrogen is, atomically speaking, number one. It comes first in the periodic table, it's the lightest of elements and it's the most abundant element in the universe. It is invisible, odorless, and non-toxic.
- c. Hydrogen can be extracted from the reformation of hydrocarbon fuels or the electrolysis of water. If hydrocarbon fuels are used for producing hydrogen using a reformer, the process does generate greenhouse gases. If electrolysis is used for producing hydrogen, the process is clean and sustainable with no greenhouse gas emissions. But the electrolysis process consumes a large amount of electricity. Indirectly it also contributes to the greenhouse gasses depending on the sources used to produce electricity. However, if the electricity comes from a renewable energy source such as wind or solar power, the net environmental impact is zero. Most hydrogen gas produced in the world today comes from a reformation process.

1.5 Advantages of Fuel Cells

Fuel cells have many advantages over conventional electricity generation systems.

1.5.1 Higher Efficiency

Fuel cells are driven by electrochemistry, not combustion, and therefore are more efficient than conventional power plants (direct energy harvesting). For example, a conventional combustion-based power plant generates electricity at 33-35% efficiency, whereas fuel cells produce energy at up to 60% efficiency. In transportation, hydrogen fuel cells can reduce fuel consumption by 50%.

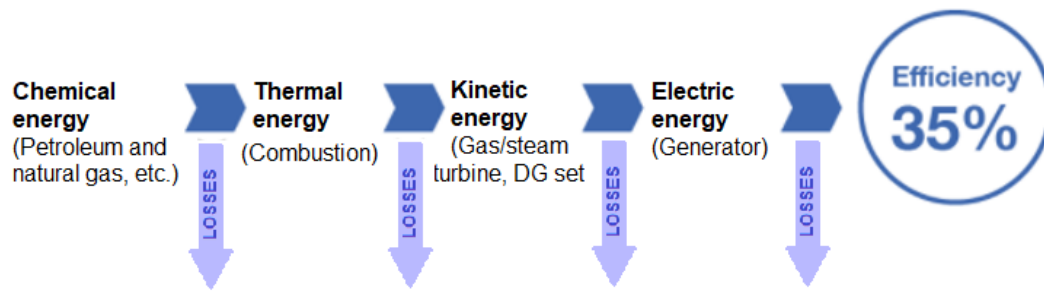

Figure 2. Conventional methods of generating power

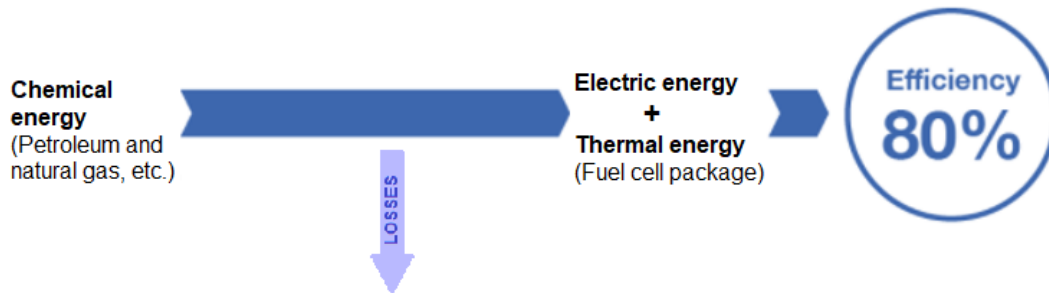

Figure 3. Fuel-cell-package methods of generating power

To push the efficiency even higher, a fuel cell can be coupled with a combined heat and power (CHP) system, which utilizes the cell's waste heat. The overall energy efficiency can be as high as 80 percent. The distributed power generation straight at the point of use can further reduce the energy losses associated with long-range grid transmission.

1.5.2 Environment Friendly

Fossil-fueled power plants and vehicles emit the most CO₂ and other greenhouse gases. Fuel cells are driven by electrochemistry, not combustion. As a result, hydrogen fuel cells do not emit

greenhouse gases. They are a naturally pure source of energy, generating just heat and water as waste products.

The table below compares the emissions profile of a fuel cell versus other forms of distributed and central power generation.

Generation Technology	NO_x (lbs/MWh)	SO₂ (lbs/MWh)	Particulate Matter (lbs/MWh)	CO₂ (Tons/MWh)
Fuel Cells*	0.01	0.001	None	0.49
Diesel Generators	5.9-17.1	0.3-0.5	0.74-3.0	0.75-0.9
Combined Cycle Natural Gas	0.11	0.022	0.067	0.50
Pulverized Coal	0.69	1.41	0.28	0.97 *

Table 1. Emissions profile of a fuel cell versus other forms of distributed and central power generation

*Assumes internal conversion of natural gas to hydrogen within the fuel cell. For pure hydrogen as a fuel there are no emissions.

Source: National Fuel Cell Research Center

If a fuel cell uses natural gas or another hydrogen-rich fuel, a reformer is used to obtain hydrogen. A small amount of NO_x, SO_x, and CO₂ is released per kWh of power generated – significantly less than typical fossil fuel generation. When pure hydrogen is used as the fuel, the only by-products are water and heat. There is no particulate, CO₂, and NO_x production with its use. This makes fuel cells potentially carbon neutral and highly efficient.

1.5.3 More Powerful and Energy Efficient than Fossil Fuels

Hydrogen fuel cell technology provides a high-density source of energy with good energy efficiency. Hydrogen has the highest energy content of any common fuel by weight. High pressure gaseous and liquid hydrogen have around three times the gravimetric energy density (around 120 MJ/kg or 51,590 Btu/lb.) of diesel and LNG and a similar volumetric energy density to natural gas.

1.5.4 Quiet and Vibration Free

Hydrogen fuel cells do not produce noise pollution due to no internal moving parts. Noise levels from a fuel cell system with a reformer are roughly 60 dB at one-meter distance.

This also means that much like electric cars, hydrogen-powered vehicles are much quieter than those that use conventional internal combustion engines.

1.5.5 Scalable

Fuel cells are scalable. The current produced by a fuel cell is proportional to the electrode area, hence stacking fuel cells increases the potential output.

To produce higher voltages, fuel cells are connected in series. The number of cells in a stack depends on the desired power output and individual cell performance. Because generator systems are so modular, it's easy to find and replace a broken or defective fuel cell. This function saves on maintenance.

1.5.6 Reduced Space

Stationary fuel cell devices also take up significantly less area in proportion to other renewable energy sources. For instance, a 10 MW fuel cell system can be sited in around an acre of land. This is compared to around 10 acres required per MW of solar power and about 50 acres per MW of wind power.

1.5.7 High Responsivity

A fuel cell can be started and run at maximum power in 30 minutes. Load variation has no effect on efficiency as long as it is over 30%.

1.5.8 System Availability

Fuel cell systems are perceived as low-maintenance devices. Fuel cells in North America have been recorded achieving more than 90 percent availability. In premium power applications, 100 percent customer power availability, and 95 percent+ fleet availability has been reported during the same period. They are particularly useful in high load factor (baseload) situations.

1.5.9 Long Life

Fuel cells have a projected life of 40,000 hours of operation at full load.

1.5.10 Fuel Flexibility

The ideal fuel for fuel cell operation is hydrogen, although many alternative hydrogen-rich fuels can be reformed to produce hydrogen. Some fuel cells even can be fueled directly with methanol, without using a reformer.

1.6 Disadvantages of Fuel Cells

1.6.1 High Costs

Precious metals such as platinum and iridium are typically required as catalysts in fuel cells, which means the high capital cost of fuel cells. Secondly, the fuel used is hydrogen. The costs of production, compressing, transporting, and storing the hydrogen fuel raise the operating costs significantly.

1.6.2 Bad Infrastructure

Despite being the most abundant element in the universe, hydrogen does not exist naturally in the environment and must be extracted from other substances that contain hydrogen such as methanol, gasoline, natural gas, or water.

The current infrastructure does not support hydrogen production, transportation, storage, and distribution. A flowchart below depicts the hydrogen production, distribution, and application.

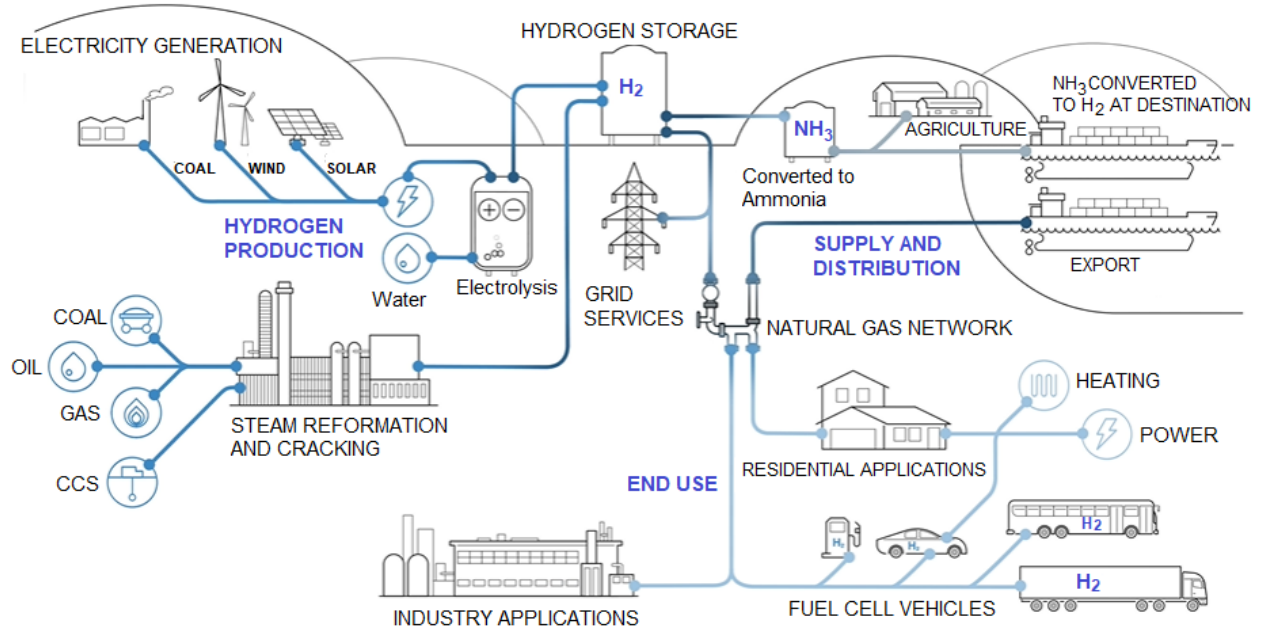

Figure 4. Hydrogen Generation, Storage, Distribution & Applications

Source: Cummins

1.6.3 Life Cycle and Reliability

Fuel cells need clean, pure fuel devoid of impurities. These impurities include sulfur and carbon compounds, as well as residual liquid fuels that can deactivate the fuel cell catalyst effectively destroying its ability to operate.

Fuel cells generate pure water during the power generating reaction. Left to freeze, any remaining water in the fuel cells will permanently destroy the cells. In normal conditions, fuel cell systems generate enough heat to prevent freezing, but in cold weather, the fuel cells must be kept warm, or the residual water must be removed before freezing.

Fuel cells that use proton exchange membranes must not dry out during use. These must remain moist during storage. Attempts to start or operate these fuel cells under dry conditions can destroy the membrane.

1.6.4 Complex Controls

Fuel cells require complex support and control systems. Fuel cells themselves are solid- state devices, but the systems required to support fuel cell operation are not.

1.6.5 Hydrogen Safety

Hydrogen is extremely flammable. It burns in air at concentrations ranging from 4 to 75% and can form explosive mixtures when mixed with air (oxygen). Some issues for plant safety, maintenance, and operation include:

- a. Explosion due to ignition of escaped biogas (CH₄, H₂S, CO, CO₂).
- b. Explosion due to ignition of escaped H₂ gas
- c. Burns due to contact with high-temperature surfaces or fluids, or frostbite due to contact with expelled gas expanding from high pressure.
- d. Equipment failures
- e. Asphyxiation if biogas, hydrogen, or nitrogen gas (used for purging of the plant) build up in a confined space with human occupancy.

The hydrogen gas utilized in fuel cell plants should be contained. Every piece of equipment must be earthed. Never lubricate a pressured system using oils.

Hydrogen diffuses quickly and may leak from a gas-tight system. Stored hydrogen must be maintained away from ignition sources and separated from other compressed gases.

The area where the fuel cell facility is operated must be continuously monitored for leakage of hydrogen gas. Continuous gas monitoring is recommended with alarm and emergency shutdown features. Such emergency shutdown mechanisms should be hardwired and recognized as safety-critical devices.

NOTE: Hydrogen gas burns with an invisible flame. In the event of fire, allow the gas to burn until the supply has been isolated and then use an extinguisher appropriate to nearby fires. Gas cylinders should be cooled using a water spray NOT a concentrated jet of water.

The containers appropriate for keeping hydrogen should go through thorough tests to make sure they are safe for the public. Extensive safety procedures and hazard reviews are needed to make the system fail-proof.

For further reading on hydrogen safety, we recommend the following resources: The Hydrogen and Fuel Cell Safety Report maintained by the Fuel Cell and Hydrogen Energy Association (www.hydrogenandfuelcellsafety.info/) and Hydrogen Tools Portal maintained by the Pacific Northwest National Laboratory (PNNL) (<https://h2tools.org/>)

1.7 Comparison of Fuel Cells with Batteries

Hydrogen fuel cells and batteries are both electrochemical cells. They each have two electrodes in contact with a material that can conduct ions, called an electrolyte. One electrode is the anode and the other is the cathode. While both batteries and fuel cells convert chemical energy into electrical energy, batteries store this chemical energy inside the battery itself. This means that a battery will run down, or need recharging when there is no longer enough stored chemical energy available to produce sufficient electricity to power the device connected to the battery. Rather than storing chemical energy inside itself, a hydrogen fuel cell gets a supply of chemical energy from the outside. This chemical energy is stored in the hydrogen that is supplied to the anode of the fuel cell. A hydrogen fuel cell essentially consumes hydrogen and oxygen. When a fuel cell is continuously supplied with hydrogen and oxygen, and the product water is removed, the fuel cell can generate electricity.

Further, the anode and cathode of a battery are consumed during use because the battery electrodes actively participate in the conversion of chemical energy to electrical energy, and over time this can have a damaging effect on the electrodes and therefore on the effectiveness of the battery. Unlike batteries, the electrodes in hydrogen fuel cells are relatively stable since they act as catalysts in the release or acceptance of electrons and are not chemically changed during this process.

1.8 Comparison of Fuel Cells with Heat Engines

Fuel cells and heat engines (e.g., internal combustion engines or gas turbines) share similarities in a way that both use gaseous fuel, drawn from an external fuel storage system. Both systems use

hydrogen-rich fuel. Fuel cells use pure hydrogen or a reformed gas mixture. Heat engines typically use carbon and hydrogen containing fossil fuels.

In some respects, fuel cells and heat engines are fundamentally different.

Fuel Cells

Chemical Energy \Rightarrow Electrical Energy

Turbine Generators

Chemical Energy \Rightarrow Heat \Rightarrow Mechanical Energy \Rightarrow Electrical Energy

Heat engines are mechanical devices that generate mechanical energy while fuel cells, like batteries, are solid-state devices that react chemically to generate electrical energy.

Heat engines convert chemical energy into heat by way of combustion and use that heat to do useful work. Fuel cells convert a fuel's chemical energy directly into electricity without raising the temperature of the working fluid such as air in the combustion process. Because the energy conversion in fuel cells is accomplished in a single direct conversion process, much higher efficiencies are possible than with conventional electricity generation by means of turbine generators which involve three energy conversion processes. The energy released in a fuel cell by a chemical reaction is determined by the change in Gibbs free energy.

The efficiency characteristics of fuel cells compared with other electric power generating heat engine systems is shown in the figure below.

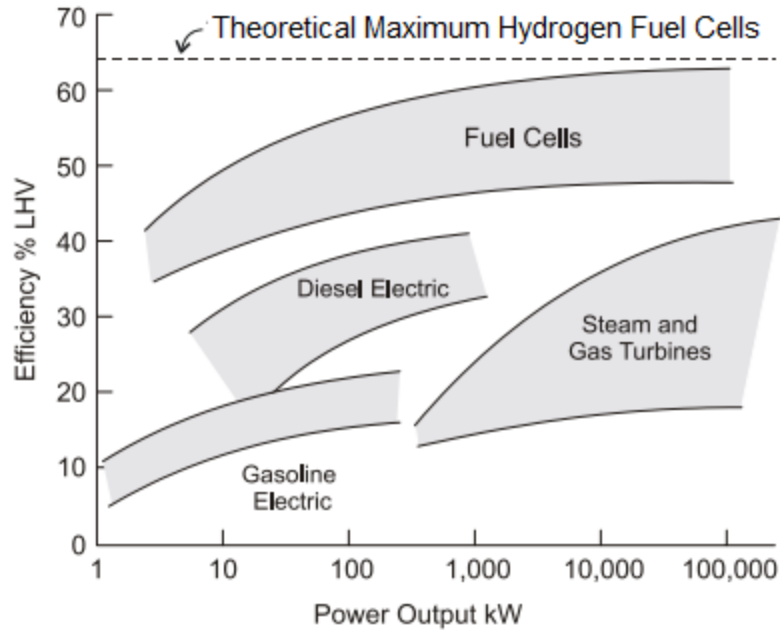

Figure 5. Efficiency Characteristics

1.9 Key Features of Fuel Cells

The features that make fuel cell systems a leading prime mover for energy applications are:

1.9.1 Fuels

The following fuels can be used:

- Natural Gas – methane from the pipeline.
- Liquefied petroleum gas (LPG) – propane and butane mixtures.
- Sour gas - unprocessed natural gas as it comes directly from the gas well.
- Biogas – any of the combustible gases produced from biological degradation of organic wastes, such as landfill gas, sewage digester gas, and animal waste digester gas.
- Industrial waste gases – flare gases and process off-gases from refineries, chemical plants, and steel mill.
- Manufactured gases – typically low- and medium-Btu gas produced as products of gasification or pyrolysis processes.

1.9.2 Flexibility

This flexibility is mostly dependent on the operating temperature of the fuel cell. In principle, the higher the temperature the less pure fuel/gas can be used.

1.9.3 Electrical Output

The fuel cell typically generates about 0.6 Volts to 0.7 Volts DC per cell at full load.

To provide greater voltage and power, a greater number of cells is placed in series creating a structure called cell stack. Increasing the active area of individual cells manages current flow. Depending on the fuel cell and the application power requirements, cell area can range from 100 cm² to over 1 m².

1.9.4 Current and Power

The current output from a single cell is directly proportional to the area of the electrodes.

As with batteries, the effective area of the electrodes and hence their potential current carrying capacity can be increased without increasing their physical size by making the surface porous and using materials with very fine particle size.

Typical power outputs are about 1 Watt /cm² of electrode plates.

1.9.5 Dynamic Response

Low-temperature fuel cells operate at around 80°C, which allows reasonably fast warm-up times (10 to 20 seconds) compared with high-temperature fuel cells which take as much as 30 minutes to reach their operating temperature of 700 to 1000°C.

Low-temperature fuel cells find applications for automotive applications which require quick start-ups. High-temperature fuel cells find application for stationary power generation.

1.9.6 High-Quality Power

Electrical output is computer-grade power, meeting critical power requirements without interruption. This minimizes lost productivity, lost revenues, product loss, or opportunity cost.

1.9.7 Efficiency

Efficiencies of present fuel cell plants are in the range of 30 to 55 percent based on the lower heating value (LHV) of the fuel. The waste heat from the fuel cell can be used in combined heat and power (CHP) applications that can offer efficiencies greater than 70 percent.

Another key feature of the fuel cell is that their performance and cost are less dependent on the scale than other power technologies. Small fuel cell plants operate nearly as efficiently as large ones, with equally low emissions, and comparable cost.

1.9.8 Size Range

Fuel cell systems are constructed from individual cells that generate 100 W to 2 kW per cell. This allows systems to have extreme flexibility in capacity. Multiple systems can operate in parallel at a single site to provide incremental capacity.

1.9.9 Availability

Commercially available systems have demonstrated greater than 90% availability.

1.9.10 Part-load Operation

Fuel cell stack efficiency improves at lower loads, which results in a system electric efficiency that is relatively steady down to one-third to one-quarter of rated capacity.

1.9.11 Reliability and Life

While the systems have few moving parts, stack assemblies are complex and have had problems with seals and electrical shorting. Stack rebuilds are required every 5-10 years.

We will learn more about the technology and applications in this course.

2 CHAPTER -2: APPLICATIONS OF FUEL CELLS

Fuel cells are inherently modular and therefore lend themselves to a wide range of applications, from large stationary powerplants to small portable power packs for backup supplies or remote areas, which are off-grid. These are also widely used for automotive applications – both hybrid and electric vehicles.

Fuel cells have three main applications:

- a. Transportation
- b. Portable uses
- c. Stationary power installations

2.1 Transportation

Fuel cells can power our vehicles including personal vehicles, trucks, buses, and marine vessels, as well as provide auxiliary power to traditional transportation technologies. Hydrogen can play a particularly important role in the future by replacing the imported petroleum we currently use in our cars and trucks.

In a vehicle that operates from an internal combustion engine the energy flow is as follows:

- Chemical Energy → Thermal Energy → Mechanical Energy (+ Fuel emissions)

In a vehicle that operates from a fuel cell the energy flow is:

- Chemical Energy → Electrical Energy → Mechanical Energy (+ Water)

Fuel cells driven vehicles have several properties that make them suitable for many transport applications.

- a. FCVs are zero-emission vehicles – they produce no tailpipe pollution except water vapor
- b. Fuel cell vehicles (FCV) are up to three times more energy-efficient than conventional vehicles
- c. A hydrogen vehicle has the same range as those that use fossil fuels (around 300 miles). This is superior to that currently offered by electric vehicles (EVs), which are increasingly being developed with fuel cell power units as ‘range-extendors’. Hydrogen fuel cells are

also not significantly impacted by the outside temperature and do not deteriorate in cold weather, unlike EVs. This advantage is increased further when coupled with the short charging times.

- d. The refueling time is three-five minutes maximum
- e. FCVs have no internal moving parts, are quiet and greatly reduce greenhouse gas carbon emissions.

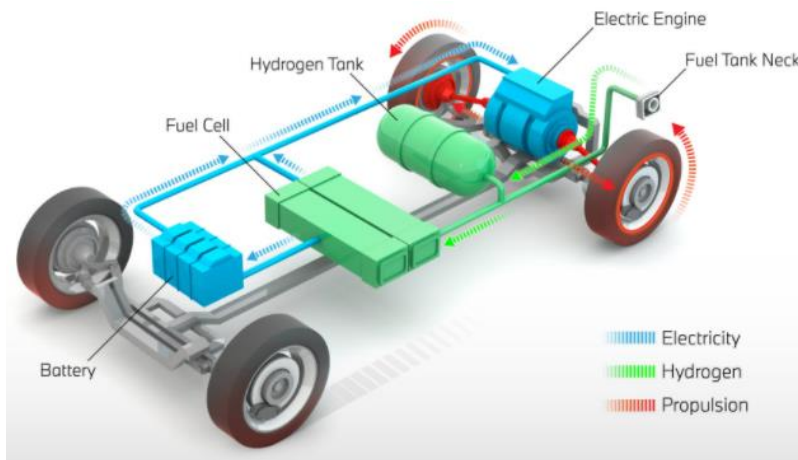

Figure 6. Fuel Cell Vehicle

Caution: Transport applications tend to demand rapid start-up and instant dynamic response from fuel cell systems, so a high-temperature fuel cell is unlikely to be competitive in this instance and operates at low temperatures typically less than 100°C.

Many major car companies are engaged in automotive fuel cell programs including Daimler-Chrysler, Ford, General Motors, Nissan, Mazda, Subaru, Toyota, Honda, and Hyundai.

Figure below shows a few fuel cell vehicles.



Fuel cell car – Toyota Mirai



Fuel cell scooter –
Suzuki Burgman



Fuel cell passenger cart – Istanbul, Turkey



Fuel cell forklift –
Istanbul, Turkey

Figure 7. Fuel cell vehicles

Fuel cells are not just confined to the utility vehicles – aerospace, locomotives, ships, submarines, unmanned aerial vehicles and a whole host of other applications offer the potential for a variety of fuel cell systems. For ships and trains, which is almost akin to having a stationary power plant running constantly, the fuel cell application ensures minimum noise, emissions, and vibration.

Of the technologies being studied for use in automobiles, the PEMFC technology offers the most promising results.

2.2 Stationary Power

Stationary fuel cells are designed to provide a clean, reliable source of power in varied applications, such as hospitals, hotels, airports, military bases, large office buildings, manufacturing sites, wastewater treatment plants, and institutions to meet the following requirements:

- a. On-site energy
- b. Continuous power – backup
- c. Uninterrupted power supply
- d. Premium power quality

e. Independent power source

One characteristic of fuel cell systems is that their efficiency is nearly unaffected by size. This means that smaller plants (several hundred kW to 1 to 2 MW) can be developed at the user's facility and the larger, dispersed plants (1 to 10 MW) can be used for distributed generation and cogeneration system in which excess heat released during electricity generation is used for other applications.

The plants are fueled primarily with natural gas and use high-temperature fuel cells.

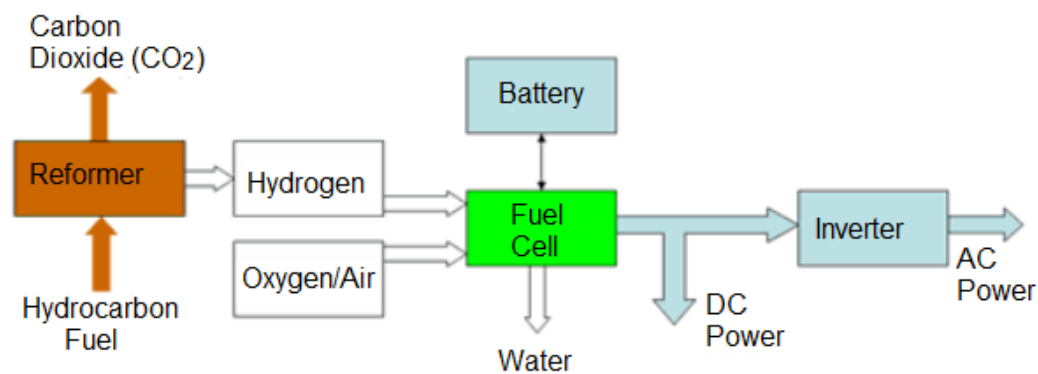

Figure 8. Fuel Cells for Power Generation & Storage

The United States, Germany, and Japan have the greatest number of stationary fuel cell power stations. Many companies around the country are adopting fuel cells for primary and backup power including Adobe, Apple, AT&T, CBS, Coca-Cola, Cox Communications, Delmarva Power, Honda, Microsoft, Target, and Walmart, among others. Google and eBay, Mountain View, CA are among the companies that have been beta-testing the solid oxide fuel cells recently introduced by Bloom Energy. These companies use huge amounts of consistent electricity to power their server farms and need to provide extensive back-up systems to keep them running in case of power outages. The fuel cells can serve both needs by providing a reliable source of baseload power.

The figure below shows some stationary power fuel cells.



Bloomenergy – 200 kW SOFC –
California, USA



FuelCell Energy – 300 kW MCFC –
Connecticut, USA



Ballard – 1.1 MW PEMFC –
California, USA



UTC – 400 kW PAFC –Connecticut,
USA

Figure 9. Stationary power fuel cells

2.2.1 Regulatory Standards

A series of standards are available to facilitate the application of stationary fuel cell technology power plants. The prominent ones include:

- a. Fuel Cell Power Systems ANSI/CSA America FC1-2004
- b. Stationary Fuel Cell Power Systems - Safety IEC TC 105 Working Group #3
- c. Stationary Fuel Cell Power Systems - Installation IEC TC 105 Working Group #5
- d. Interconnecting Distributed Resources IEEE P1547.1, P1547.2, P1547.3, P1547.4
- e. Test Method for the Performance of Stationary Fuel Cell Power Plants IEC TC 105 Working Group #4

2.3 Portable Power Systems

Fuel cells can power almost any portable device or machine that uses batteries. Unlike a typical battery, which eventually goes dead, a fuel cell continues to produce energy as long as fuel and oxidant are supplied. Radios, laptops, cellular phones, cameras, video recorders, mp3 players,

portable chargers, toys, educational kits, and military gadgets could be powered by portable fuel cells.

Portable fuel cells are lightweight, long-lasting power sources that extend the time a device can be used without recharging. In comparison, secondary (rechargeable) batteries have battery charger systems that consist of AC chargers that require an outlet to be charged or DC chargers that will recharge your batteries from other batteries. Because rechargeable batteries are heavy and do not meet the power requirements, they are not suitable for some portable and defense electronic devices such as power tools, military equipment, battery chargers, unattended sensors, and unmanned aerial and underwater vehicles.

A notable difference between rechargeable batteries and fuel cells is that a fuel cell needs a continuous supply of fuel. Metal hydrides, methanol, formic acid, ethanol, and, of course, hydrogen have all been utilized in fuel cells. For portable fuel cells, methanol or ethanol can be fed directly into the cell, or a fuel reformer can be attached to the fuel cell package.

There are already commercial auxiliary power units with fuel cell technology as well as toys, educational kits, and portable chargers. Figure below shows some portable applications of fuel cells.



A laptop powered by a direct methanol fuel cell



An educational fuel cell toy car



A fuel cell portable charger

Figure 10. Portable fuel cell applications

2.3.1 Fuel Cells for Your Home

While fuel cells in the United States are today targeted towards commercial use, in Europe and Japan, portable fuel cells are beginning to be manufactured and sold for the residential market. In Japan, portable fuel cells, about the size of a refrigerator, are being sold for \$30,000 (\$15,000 after government subsidy). To date, about 5,000 of the units have been installed. But, with mass production, analysts expect the cost to drop to about \$5,000 within five years and one in four homes in Japan to have them by 2050. Beyond reducing dependency on the electric grid, converting natural gas into electricity (with the waste heat being used for space and hot water heating) would save homeowners a considerable amount in energy costs and reduce the net carbon emissions of a home.

2.4 Combined Heat and Power (CHP) Applications

Fuel cells can be made even more efficient through cogeneration – i.e., combined heat and power (CHP) systems. A CHP system consists of a prime mover, an electricity generator, a heat recovery system, and a control system. The prime mover generates electricity via driving the generator and creates usable heat that is recovered and used for heating purposes. Another benefit of CHP is being able to utilize almost any primary fuel depending on the prime mover. Some prime movers can even use multiple fuel types, which provides flexibility against price volatility and addresses energy security concerns.

Since power and generation is combined and located at/close to point of use, CHP systems have smaller losses and may reach much higher total efficiency levels.

Primary applications for CHP in the commercial/institutional sectors are those building types with relatively high and coincident electric and hot water/space heating demand such as colleges and universities, hospitals, nursing homes, and lodging. Cogeneration systems can reach 80% efficiency (of which 40-60% is electric).

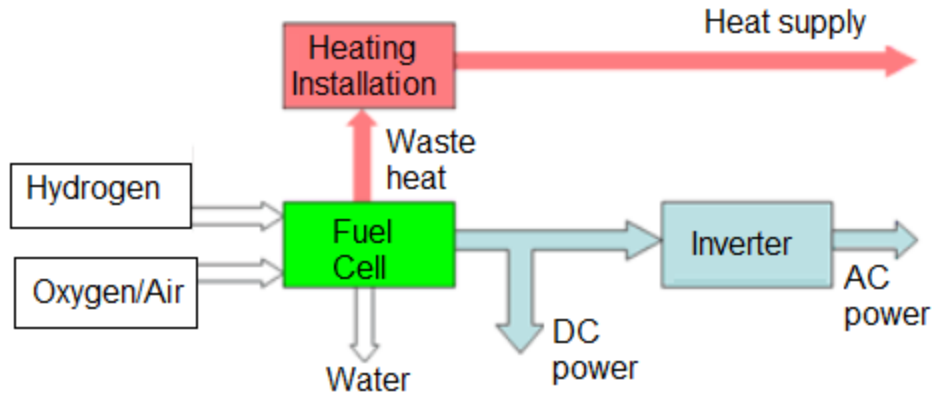

Figure 11. Fuel Cells in CHP Applications

2.5 Other Applications

The uses listed above are just some of the examples of where fuel cells could be used. Other applications include power for base stations and telecommunication sites, distributed power generation, emergency power systems as a backup for when other systems fail, telecommunications, base load power plants, portable charging stations for small electronic devices, small heating appliances, food preservation for shipping containers (exhausting the oxygen through power generation), and electrochemical sensors.

Thermally driven cooling systems are designed to use heat for cooling purposes using absorption chillers. Although compared to conventional vapor compression refrigeration systems, they have lower efficiency (coefficient of performance, COP) and higher capital costs, their ability to utilize waste energy makes them attractive especially when there is a large amount of waste heat available.

Fuel cells have been used in NASA spacecraft since the Gemini program in the 1960s and even today they provide electricity and drinking water for astronauts on Space Shuttle flights.

3 CHAPTER -3: TECHNOLOGY DESCRIPTION

Fuel cells produce direct current (DC) electricity through an electrochemical process, much like a standard battery. Unlike a standard battery, a fuel supply continuously replenishes the fuel cell. The reactants, usually hydrogen and oxygen gas, are fed into the fuel cell reactor, and power is generated. The hydrogen (H_2) typically comes from a hydrocarbon fuel like natural gas or LPG, while the oxygen (O_2) comes from the air.

3.1 Hydrogen Fuel Cells

Hydrogen fuel cells generate electricity through a chemical reaction of hydrogen and oxygen without combustion, creating zero emissions. Hydrogen gas is passed through a fuel cell stack where the pure hydrogen mixes with atmospheric oxygen to generate electricity.

A typical hydrogen fuel cell works in the following way:

Hydrogen fuel flows into the anode side of the fuel cell while oxygen in the air is introduced to the cathode side. At the anode, the reactions break down the hydrogen molecules into protons (hydrogen ions) and electrons.

Both types of ions are naturally drawn to the cathode, but only the protons (H^+ ions) can pass through the electrolyte membrane to the cathode. The negatively charged electrons are forced to travel through an external circuit to the cathode and produce an electric current that can power an electric load.

At the cathode, the catalyst breaks down the oxygen molecules and facilitates the electrochemical reaction that combines oxygen, protons, and electrons to produce water and heat.

The figure below illustrates the electrochemical process in a typical fuel cell.

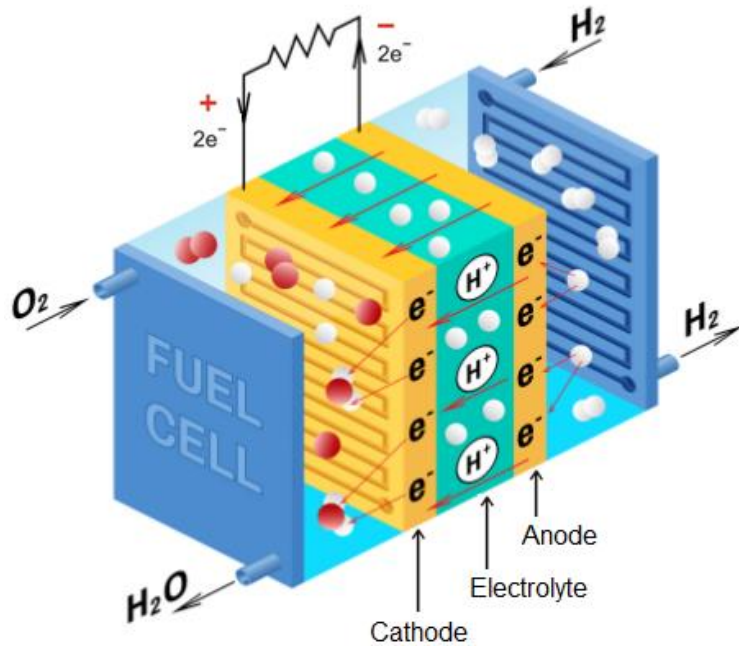
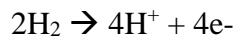

Figure 12. Generic Hydrogen Fuel Cell Operation

3.1.1 Reactions

Anode Reaction

At the anode, the hydrogen gas is electrochemically dissociated (in the presence of a catalyst) into hydrogen ions (H^+) and free electrons (e^-).



The electrons flow out of the anode through an external electrical circuit. The hydrogen ions flow into the electrolyte layer and eventually to the cathode, driven by both concentration and potential forces.

Cathode Reaction

At the cathode, the oxygen gas is electrochemically combined (in the presence of a catalyst) with the hydrogen ions and free electrons to generate water.

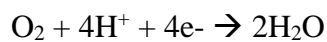

Net Cell Reaction

Individual reactions at the anode and cathode always remain balanced, which means that the same number of electrons are gained and lost. The overall reaction in a fuel cell is:

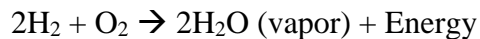

The reaction rate of this electrochemical reaction is quite low. This issue is overcome with the help of a catalyst such as platinum or palladium. To increase the effective surface area, the catalyst is finely divided before being incorporated into the electrodes.

3.1 Fuel Cell Stack

The fuel cell's output power is the product of current (amps) and operational voltage (V). A typical fuel cell provides a voltage between 0.6 and 0.7 V at full load. Many individual single cells can be combined into a fuel cell stack and connected electrically in series or parallel to produce the voltage and current level desired. They are stacked one on top of the other. The number of fuel cells connected in series determines the stack voltage because, in series, the total voltage equals the sum of individual voltages.

For a stack of fuel cells, since each individual cell has the same voltage, we just need to multiply that voltage with the number of single cells to calculate the total voltage of the stack. The number of the cells connected in parallel determines the total currents produced because, in parallel, the total current equals the sum of individual currents. Then the power can be found as the product of the current and the voltage.

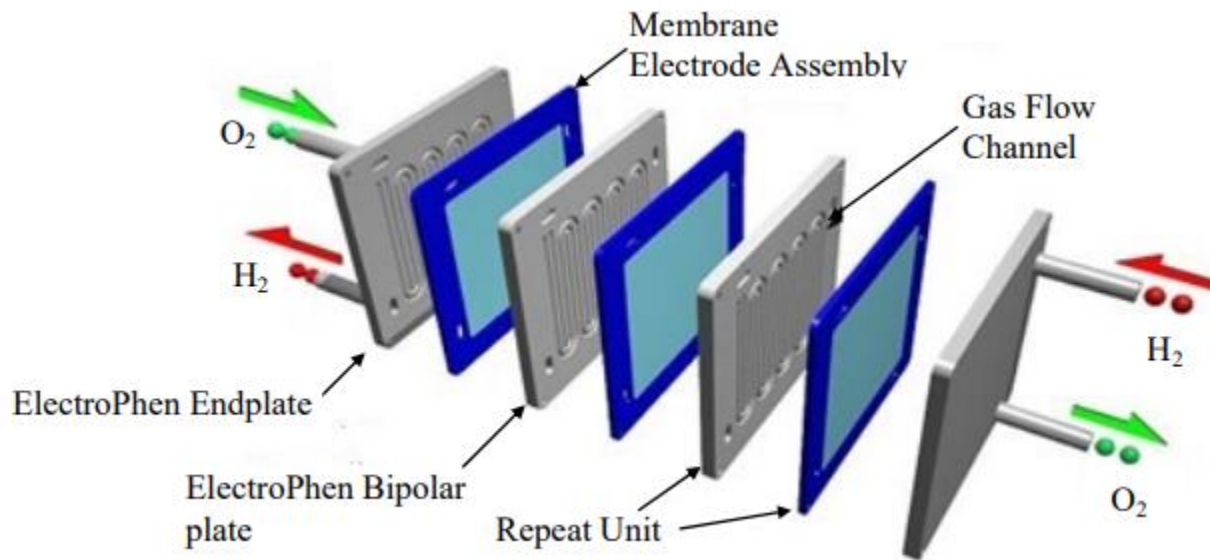

Figure 13. PEMFC Cell Stack

3.2 Main Components of Fuel Cell

3.2.1 Electrodes

A typical single fuel cell is comprised of two oppositely charged electrodes on two sides and an electrolyte in the center. The anode is negatively charged and repels electrons. The cathode is positively charged and attracts electrons. Electrodes are commonly formed of porous, hydrophobic (non-wettable), conductive, and non-corrosive carbon fiber paper. The material is very thin to maximize gas and water transport.

The ideal electrodes have the following properties:

- Good electrical conductors
- Highly resistant to a corrosive environment
- Should perform charge separation
- It should not take part in chemical reactions

3.2.2 Electrolyte

The electrolyte is a material that transports charged ions from one electrode to the other.

The primary requirement is that the electrolytes must have strong ionic conductivity while remaining electrically non-conductive to avoid short-circuiting the anode and cathode. For example, the membrane-type electrolyte in PEMFC solely transmits positively charged ions and blocks the passage of electrons. The electrolyte should not react with any of the reactants or products of the process and should be inaccessible for gases to prevent undesired reactions.

3.2.3 Catalyst

The catalyst is coated at the interface of each electrode with the electrolyte. The catalyst is used to speed up the electrochemical reaction. Therefore, the type of catalyst used depends upon the operating temperature of each type of fuel cell. Generally, high operating temperature fuel cells can use common metals as a catalyst, but the low operating temperature fuel cells require noble metals as a catalyst, typically platinum because at low-temperature noble metals like platinum has a better ability to break the hydrogen bonding than common metals because of the outer layer of the electron configuration.

Caution: The platinum catalyst used in Proton Exchange Membrane Fuel Cell (PEMFC) some other cells is extremely sensitive to poisoning by even small amounts of Carbon Monoxide making it necessary to employ additional filtering processes in the system to eliminate potential contaminants.

3.3 Fuel Cell Types & Construction

There are five principal types of fuel cells:

- a. Proton Exchange Membrane Fuel Cell (PEMFC)
- b. Molten Carbonate Fuel Cell (MCFC)
- c. Solid Oxide Fuel Cell (SOFC)
- d. Phosphoric Acid Fuel Cell (PAFC)
- e. Alkaline Fuel Cell (AFC)

An electrolyte and two electrodes are the essential components of all fuel cells, but the electrolyte is what differentiates them.

The electrolyte is a substance that conducts ions but not electricity. It can be a membrane, a liquid solution, or a solid depending on the type of the fuel cell. For instance, PEM fuel cells use a water-based or mineral-acid-based polymer membrane as an electrolyte. SOFCs use a non-porous metal oxide as the electrolyte while phosphoric acid fuel cells (PAFCs) utilize a concentrated 100% phosphoric acid liquid as the electrolyte. As a result, the conduction mechanisms are different. SOFCs have ionic conductions accomplished by oxygen ions while PAFCs have the permeation of hydrogen ions through the electrolyte layer.

We will learn more details about these sub-components in subsequent chapters.

3.4 Fuel Cell Subsystems

The block diagram below represents a fuel cell power generation plant. It comprises four basic components:

- a. A fuel processor
- b. Power section - an energy conversion device
- c. Power conditioner - current converter
- d. Heat recovery system

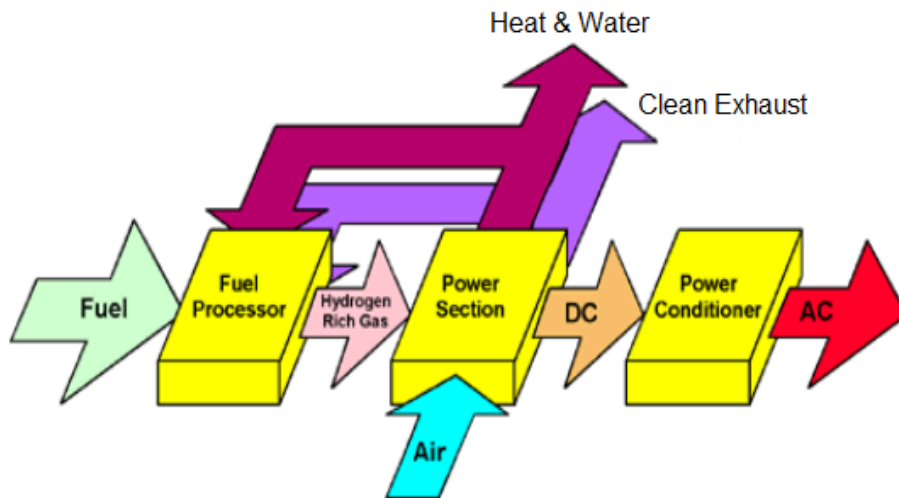

Figure 14. Fuel cell power plant

3.4.1 Fuel Processor or Reformer

Stationary power generation uses high-temperature fuel cells fed by hydrocarbons like natural gas. To turn natural gas into hydrogen-rich gas, a fuel processor (also called reformer) is necessary. Fuel is introduced into a processor, which produces hydrogen-rich gas from natural gas or other fuels, emitting carbon dioxide and a trace amounts of carbon monoxide compounds called “reformat”.

If hydrogen is fed to the system, a processor may not be required, or it may only be needed to filter impurities out of the hydrogen gas. In many cases, the reformat is then sent to another reactor to remove impurities, such as carbon oxides or sulfur before it is sent to the fuel cell stack. This prevents impurities in the gas from binding with the fuel cell catalysts. This binding process is also called “poisoning” since it reduces the efficiency and life expectancy of the fuel cell.

Depending on the types of fuel cells and their operating temperature, the reformer can be internal or external. For example, high operating temperature fuel cells such as molten carbonate and solid oxide fuel cells do not require external reformers; they can be reformed internally.

There are three primary types of reformers:

- a. Steam reformers
- b. Autothermal reformers
- c. Partial oxidation reformers

The fundamental differences are the source of oxygen used to combine with the carbon in the fuel to release the hydrogen gases and the thermal balance of the chemical process. Steam reformers use steam, while partial oxidation units use oxygen gas, and autothermal reformers use both steam and oxygen.

- a. Steam reforming is highly endothermic and takes a lot of heat input.
- b. Autothermal reformers typically operate at or near the thermal neutral point, and these do not generate or consume thermal energy.
- c. Partial oxidation units partially oxidize the fuel (i.e., combust a portion of the fuel), releasing heat in the process.

Since the reformer is an endothermic catalytic converter and the fuel cell is an exothermic catalytic oxidizer, the two combines into one with mutual thermal benefits.

3.4.2 Power Section

After the reforming process, the hydrogen-rich gas and oxygen from airflow into a power section where direct current is generated from electrochemical reactions that take place in the fuel cell. Water and heat are also produced.

3.4.3 Power Conditioner

Fuel cells produce direct current (DC). The power conditioner consisting of an inverter converts the direct current (DC) electricity to alternating current (AC) electricity for suitable use in most electrical devices. The power conditioner is used to control current flow, voltage, frequency, and other characteristics of the electrical current to meet the needs of the application.

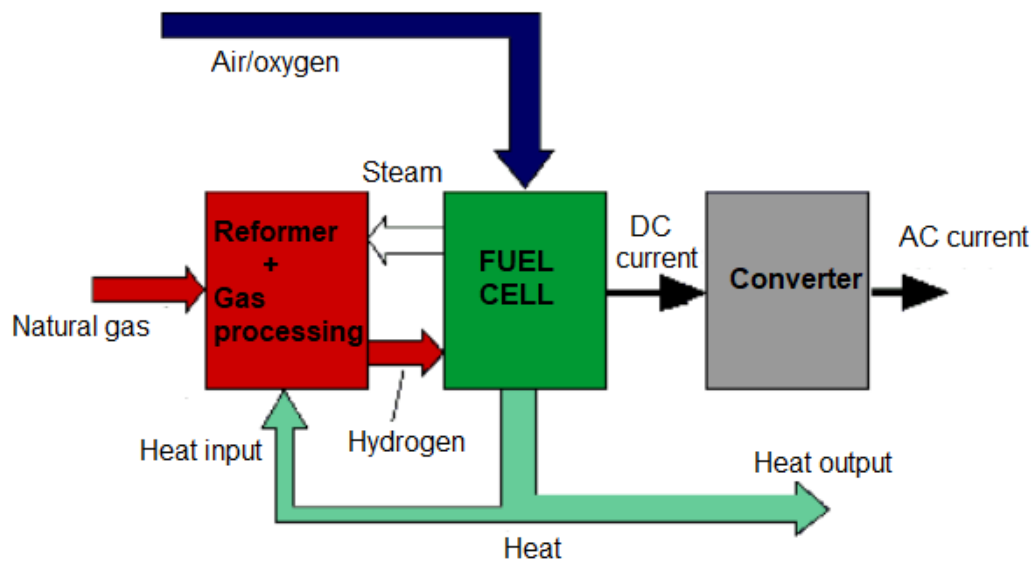

Figure 15. Heat and Power Flows within Fuel Cell System

3.4.4 Heat Recovery System

A heat recovery system is typically used in high-temperature fuel cell systems. The excess heat generated by high-temperature fuel cells can be used to produce steam or hot water or can be converted to electricity via a gas turbine or other technology. This cogeneration can increase the

overall thermal efficiency of the systems. A vapor absorption chiller machine can be used to generate chilled water using the waste heat.

3.5 Balance of Plant (BOP)

The fuel cell stack alone cannot generate electricity. Practical systems require sub-systems to supply fuel and control the energy conversion processes. The "balance of plant" is as expensive and complex as the fuel cell stack itself. Some of this equipment is outlined below.

3.5.1 Fuel Supply or Storage

When natural gas is used as a fuel, the hydrogen generation is carried out on-site using a "Reformer". The reformer is the largest device requiring big storage capacity to store the reformat fuel.

If Hydrogen generation is not part of the system, there must be some form of storage to carry the Hydrogen fuel to be consumed by the fuel cell. This requires expensive high-pressure tanks or cryogenic storage tanks.

3.5.2 Pumps, Compressors, and Expanders

Pumps are needed to pump the reactant air through the stack and to provide forced cooling.

Higher power systems require compressors to handle the higher airflow rates.

Expanders are needed to reduce the high pressure of the stored hydrogen to the required input pressure at the stack.

3.5.3 Filters

Filters are required to remove pollutants from the fuel that could harm the catalysts or damage the cells, lowering power output and eventually causing their shut down. Particular offenders are Carbon Monoxide, resulting from incomplete reactions in the reformer, which affects the platinum catalysts, and Sulphur found in reformates derived from fossil fuels, such as coal, oil, and natural gas, which contaminates the Hydrogen gas and in turn attacks and degrades the anodes.

3.5.4 Thermal Management

High power systems use forced cooling with fluid coolants to remove the heat. This requires fluid pumps and a radiator/heat exchanger to expel the heat.

The system also requires heaters to bring the stack temperature up to its operating point on startup.

An overall thermal management system is required to balance the heat flows to keep the temperature of the stack at its optimum operating point.

3.5.5 Water Management

The conductivity of the electrolyte in the cell is proportional to the water content and it must be kept moist to remain conductive. The airflow and the heat generation in the cell tend to work against this. Consequently, the air supplied to the cell must be humidified to stop electrolyte drying out and this requires a humidifier.

Cold temperature operation in freezing conditions also brings problems due to the formation of ice crystals which can damage the electrolyte or membrane. The system must incorporate a method of purging the water or alternative anti-freeze controls.

Another pump may be required to remove surplus water from the cathode.

3.5.6 Electrical Power Management

Though some fuel cells may be required to provide a steady operating current and voltage, most systems must be responsive to variable demands. This means that the system should provide for a variable output current and consequently, all the fuel, air, and water flows must be varied accordingly. At the same time, the heat dissipation will change, and the temperature must be maintained within its designed operating range. The same will apply to the reformer if this is part of the system.

The fuel cell system output voltage is fixed but the application may require a different voltage or, in the case of most distributed power generators, an alternating current output. In these cases, DC/DC converters or AC inverters may be an integral part of the system.

3.5.7 Electric Motors

Motors of different sizes are required to drive the pumps and compressors.

3.5.8 Sensors

Sensors are required to monitor temperatures, pressures, fluid, and gas flows as well as electrical currents and voltages.

3.5.9 Battery

The fuel cell does not start to deliver electrical energy until it approaches its operating point. During startup, batteries are required to power all the electronic control systems, as well as the pumps, compressors, and heaters needed to get the stack up to its operating point.

The battery also provides an independent stable voltage to power the system electronics. Because of the slow dynamic performance of the fuel cell, the battery may also be required to provide a temporary power boost when the fuel cell is subject to sudden demand.

3.5.10 Safety Systems

Safety systems must provide fail-safe operation, protecting the system from out-of-tolerance conditions and abuse and shutting it down if necessary.

3.5.11 Control System

The system could not function without comprehensive electronic control systems to manage all the sub-systems listed above.

4 CHAPTER - 4: TYPES OF FUEL CELLS

There are different fuel cell technologies on the market, and each one is distinguished by the type of electrolyte it employs. The type of electrolyte used in each fuel cell technology impacts the operating temperature range and efficiency. Available technologies include:

- a. Polymer Electrolyte Membrane (PEMFC)
- b. Direct methanol (DMFC)
- c. Alkaline (AFC)
- d. Phosphoric acid (PAFC)
- e. Molten carbonate (MCFC)
- f. Solid oxide (SOFC)

Each fuel cell type has an optimal temperature for ionic conductivity and component stability. Operating temperatures vary from near-ambient to 1,000°C, and electrical generating efficiencies range from 30 percent to over 50 percent on a Higher Heating Value (HHV) basis.

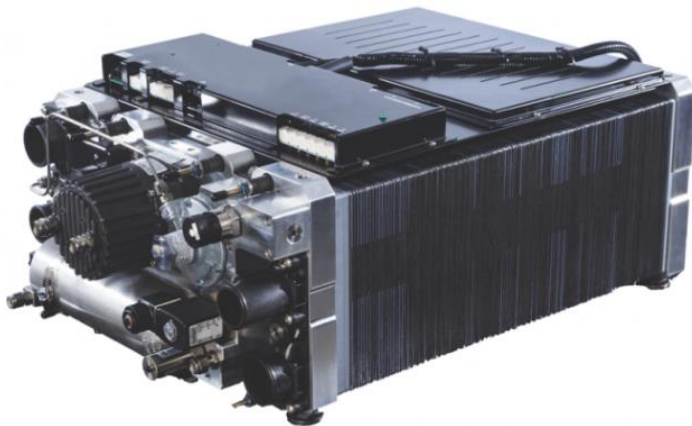

Figure 16. Fuel Cell Module

4.1 Classification of Fuel Cells

Fuel cells can be classified into two classes:

- a. High-temperature Fuel Cells (for stationary power applications)
- b. Low-temperature Fuel Cells (for transportation applications)

The low-temperature fuel cells are ideally suited to transportation applications and high-temperature fuel cells are suited to power generation. It is important to distinguish between the low-temperature and high temperature variants because it places a different demand on the fuel cell stack and system.

4.1.1 High-temperature Fuel Cells

High-temperature fuel cells reach above 600°C.

The high temperatures permit the spontaneous internal reforming of light hydrocarbon fuels — such as methane — into hydrogen and carbon in the presence of water. High-temperature fuel cells react quickly and effectively without expensive electrocatalysts like platinum. This reaction occurs at the anode over a nickel catalyst.

The high-temperature operation has drawbacks of material breakdown and slow startup, making it unsuitable for multi-fold applications. Because this technology is not appropriate for rapid startup, current high-temperature fuel cell applications are limited to stationary power generation.

High-temperature fuel cells include:

- a. Molten carbonate (MCFC)
- b. Solid oxide (SOFC)

4.1.1.1 Characteristics of High Temperature Fuel Cells

The high temperature fuel cells can be classed as having the following general features:

- a. Primary application – Stationary Power Generation
- b. Fuel flexibility: they can be operated on a range of hydrocarbon fuels.
- c. They don't require platinum as a catalyst.
- d. They can generate useful high-grade waste heat and are therefore well suited in downstream processes for cogeneration purposes.
- e. They exhibit long start-up times and are sensitive to thermal transients.

- f. They suffer from severe materials problems to withstand the operating temperature, particularly in the balance of plant (piping, heat exchangers, etc.). Few materials can work for extended periods without degradation within a chemical environment at high temperatures.
- g. Reliability and durability is a concern, again due to the operating temperature.
- h. They can be integrated with a gas turbine, offering high efficiency combined cycles.

4.1.2 Low-temperature Fuel Cells

Low-temperature fuel cells typically operate below 250°C and are suitable for vehicle applications.

The most prominent low-temperature fuel cells are:

- a. Proton exchange membrane (PEMFC)
- b. Phosphoric acid (PAFC)
- c. Direct methanol (DMFC)
- d. Alkaline (AFC)

4.1.2.1 Characteristics of Low-temperature Fuel Cells

The low-temperature fuel cells can be distinguished by the following common characteristics:

- a. Primary application – Transportation and portable devices
- b. They require a relatively pure supply of hydrogen as a fuel.
- c. They generally incorporate precious metal electrocatalysts to improve performance.
- d. They exhibit fast dynamic response and quick startup.

4.2 Fuel Cell Types

The basic chemistry of fuel cells can be modified to fulfill the various design and operating characteristics. Typically,

- a. Higher power outputs can be achieved by operating at high temperatures and by using electrodes with a greater surface area.
- b. Lower operating temperatures can be obtained by using more expensive catalysts.

4.2.1 Proton Exchange Membrane Fuel Cell (PEMFC)

Proton exchange membrane fuel cells (PEMFC or PEM fuel cells) use a water-based or mineral-acid-based polymer membrane as an electrolyte and platinum group-based electrodes.

The water-based PEM fuel cells operate at 80-100°C while the mineral-acid-based PEMs, known as high-temperature PEMs (or HTPEMs) operate at up to 200°C.

Pure hydrogen gas is the typical fuel for PEM fuel cells and have 40-60 percent efficiency range. They require precise humidity conditions to operate, and their acidic nature requires the use of a platinum catalyst.

PEM fuel cells are relatively small and lightweight and are the leading fuel cell technology in material handling applications such as forklifts and for transportation applications, including cars, buses, and trucks.

4.2.2 Direct Methanol Fuel Cell (DMFC)

Much like PEMFC, Direct Methanol Fuel Cells (DMFCs) use a polymer membrane as an electrolyte and a platinum catalyst as well. Unlike PEMFCs, they use methanol as a liquid fuel, avoiding both hydrogen supply issues and the need for an onboard reformer.

They work at temperatures between 50°C and 100°C, but their power output is minimal, limiting their use to portable electronics.

4.2.3 Alkaline Fuel Cell (AFC)

Alkaline Fuel Cells (AFC) use a liquid alkaline electrolyte such as potassium hydroxide (KOH) in water and cathodes that are usually made with platinum.

These cells operate at relatively low temperatures (approximately 60-90°C). AFCs are among the most efficient type of fuel cells, reaching up to 60% efficiency and up to 87% combined heat and power.

They are cheaper than PEMFC but produce less power. The drawback is that the catalyst is susceptible to CO₂ poisoning.

Some other advantages of AFCs include their virtually instant operation without pre-heating, even at sub-zero temperatures, and their resistance to humidity and salt air. AFCs are used as backup generators or long-duration UPSs, for powering telecom towers and urban buses. They are primarily used in controlled aerospace and underwater applications. They are best known for providing drinking water and electricity to the astronauts of the NASA Apollo expedition.

4.2.4 Phosphoric Acid Fuel Cell (PAFC)

Phosphoric acid fuel cells (PAFCs) use phosphoric acid as an electrolyte and an anode and cathode made of a finely dispersed platinum catalyst on a carbon and silicon carbide structure.

PAFCs run at a higher temperature of around 150 - 220°C range, allowing them to handle small amounts of fuel impurities. They have a relatively low efficiency of around 35%. Inefficient conversion results in significant heat output in the fuel cell stack. Water management in these fuel cells is easier than in PEMs, and they are more tolerant of impurities in hydrogen. However, the emission of phosphoric acid vapor is problematic and good ventilation is mandatory. PAFCs are less powerful than other fuel cells for the same weight and volume and require much more platinum than other fuel cells, which raises their cost.

They are one of the most mature types of fuel cells and the first type to be commercially used. They have been typically used for stationary power generation in buildings, hotels, hospitals, and utilities in the USA, Europe, and Asia.

4.2.5 Molten Carbonate Fuel Cells (MCFCs)

Molten Carbonate Fuel Cells (MCFCs) use a molten carbonate electrolyte and operate at 650 °C, which allows them to operate on unreformed fuels such as natural gas, methanol, ethanol, biogas, and coal. In addition, the absence of a catalyst made from noble metals such as gold, silver, or platinum allows MCFCs to be more cost- competitive with more traditional sources of power.

MCFCs also offer efficiency levels of close to 50%, which can be increased up to 80% when high-quality waste heat is reused. MCFCs require many stainless steel and nickel parts that increase the materials cost and that may require specialized manufacturing techniques. Molten carbonate is also inherently corrosive in nature.

Since the operating temperature is so high, MCFCs require significant time to reach operating temperature and are slow to respond to sudden changes in electricity demand. As such, they are best suited for the provision of constant power in large utility applications.

4.2.6 Solid Oxide Fuel Cell (SOFC)

Solid oxide fuel cells are made up of a very thin layer of ceramics. The ceramics used in SOFCs do not become electrically and ionically active until they reach 500-1000°C and the high temperature enables them to oxidize nearly any fuel, including gasoline, diesel, natural gas, biofuels, hydrogen, and even coal gas.

SOFC replaces the membrane and gas diffusion layer found in PEMFC with a cathode-electrolyte-anode assembly and like MAFCs, they don't need a platinum catalyst.

The ceramic construction needed to provide stability and reliability makes SOFCs more expensive than other fuel cells. The solid electrolyte is made from a ceramic material called Ytria-Stabilized Zirconia (YSZ).

Since the operating temperature is so high, SOFCs require significant time to reach operating temperature and are slow to respond to changes in electricity demand. As such, they are best suited for large stationary power generation applications.

We will learn more about the different types in subsequent chapters.

5 CHAPTER - 5: PROTON EXCHANGE MEMBRANE FUEL CELLS

PEM fuel cells (PEMFCs) are low-temperature fuel cells that use a solid polymer as an electrolyte, eliminating the need for corrosive liquids. Hydrogen is delivered as fuel into the anode side and the oxidant, normally air, into the cathode side.

The electrolyte prevents the direct reaction between the fuel and the oxidant, but it allows ions to travel across it. Accordingly, at the anode side, the hydrogen is ionized to form protons (H^+) which can cross the electrolyte, whereas, at the cathode, oxygen is reduced and forms water with protons (H^+) that are transported through the proton conductive membrane. The sub-reactions and overall reaction can be expressed by the following equations:

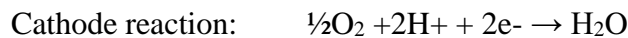

The following figure depicts the PEMFC's basic principle.

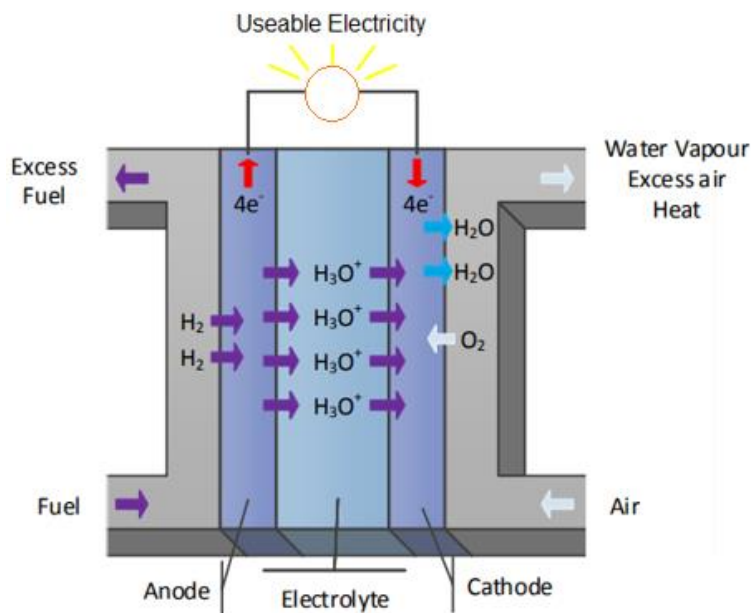

Figure 17. Basic Principle of PEMFC

PEMFCs have modest operating temperatures (70 to 90°C) and pressures 15-30 psig (1 to 2 barg). Each cell can generate 0.6-0.7 volts DC.

This technology has received the most attention due to its ease of use, and speedy start-up (low operative temperature).

PEMFC's have high power density and can vary their output quickly to meet demand. But the drawback is that at low temperatures, an electrochemical reaction requires an expensive noble metal catalyst (usually platinum). This type of fuel cell is highly sensitive to CO poisoning.

5.1 Main Components of PEMFC

Practically, the primary components of a PEM fuel cell are:

- a. The ion exchange membrane as solid electrolyte
- b. An electrically conductive, porous gas diffusion layer
- c. An electro-catalyst (the electrodes) at the interface between the backing layer and the membrane
- d. Cell interconnects and flow plates that deliver the fuel and oxidant to reactive sites via flow channels and electrically connect the cells.

Generally, the first three components are joined together to form a Membrane Electrode Assembly (MEA) which is the heart of the PEM fuel cell.

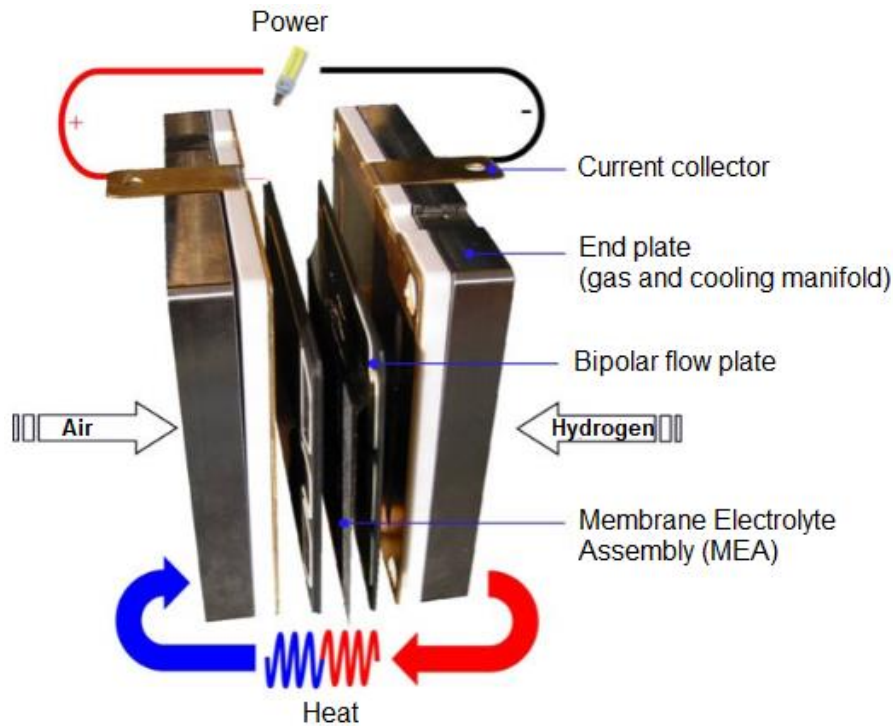

Figure 18. Structure of PEMFC

5.2 Materials of PEMFC

In this section, the engineering materials used in these main components will be explored.

5.2.1 Membrane

The membrane is a specially treated material that looks something like ordinary kitchen plastic wrap.

The membrane materials should be able to conduct only positively charged ions and blocks the electrons, and therefore, the ionic conductivity is the most important feature of electrolyte material. In addition to the high ion conductivity, the membrane should be durable, robust, and resistant to chemical attacks.

The choice of membrane materials depends on the temperature range at which the fuel cells are operating so that the membrane should have a wide operating temperature range -30°C to 200°C .

The most widely utilized membrane is “NAFION” (a proprietary product of DuPont), a sulfonated polymer containing a PFTE (Teflon). The sulfonated polymers are comprised of perfluorinated

back-bones and sulfonated sidechains. The perfluoroether is responsible for the chemical stability while the function of sulfonated sidechains is to aggregate and facilitate hydration.

The main challenges associated with the use of the perfluorinated membrane can be summarized as follow:

- a. The complicated and environmentally unfriendly production process involves toxic intermediates and waste products.
- b. Very high-cost materials (~\$700/m²)
- c. The dependence of proton conductivity on the water content of the membrane may lead to the use of humidification equipment to reach the required level of humidity.
- d. Inoperability at high temperatures.
- e. Swelling and shrinking may be occurred during the operation due to changes in water uptake during humidity and thermal cycling.
- f. Chemical degradation may happen the over long-term operation of the PEM fuel cell. This degradation is attributed to peroxide formation that attacks the membrane's structure by contaminant transition metal ions forming reactive peroxy and/or hydroxyl radicals.

Its thickness is 50-175 μm . The thinner Nafion membrane provides for better cell conductivity but complicates water management. A thicker membrane slows down the conductivity.

Significant research efforts have been made to overcome the challenges and to develop cheaper and less water-dependent membrane material.

5.2.2 Electro-Catalyst Layer

The function of electrocatalyst layer is to initiate the dissociation of the hydrogen, on the anode side, and for accelerating the oxygen reduction reaction (ORR) on the cathode side. Then, the electrons, produced on the anode side, travel through an external circuit to produce the current while the protons traverse the membrane to the cathode side of the membrane and combine with the oxygen and the electrons arriving from the external circuit to produce water and heat.

In low-temperature applications, as in PEM fuel cells which operate with pure hydrogen and air, platinum is extensively employed as a catalyst because it is the most active noble metal. Generally, the platinum-based catalyst layers are excellent for fuel cells with comparatively clean reactants.

However, the major challenge of the platinum-based catalyst arises when the hydrogen fuel contains residual mono oxide (CO). The CO poisons the Pt catalyst layer leading to a steady degradation of the fuel cell performance.

Reducing the amount of platinum in the electro-catalyst layer can reduce the overall cost of the PEMFC technology and allow for mass production. Mainly, the platinum content can be reduced either by alloying it with low-cost metals as pointed out before, or by the application of core-shell catalysts.

5.2.3 Gas diffusion layer (GDL)

The gas diffusion layer (GDL) is the outer layer of the membrane electrode assembly (MEA) and is placed between the flow plates and catalyst layer. The GDL, which is thicker than the catalyst layer, serves many important tasks in the PEMFC:

- a. Provide mechanical support for the catalyst structure and membrane
- b. conduct electrons between the bipolar plate and the electrode
- c. protect the catalyst layer from corrosion or erosion caused by flows
- d. balance water retention (for membrane conductivity) with water release (needed to keep the pores open so hydrogen and oxygen can diffuse into the electrodes)
- e. disperse the reactant uniformly from the flow plates over the catalyst layer.

To fulfil all the above functions, The GDL should have high electronic and thermal conductivity, has a porous nature, thicker than the catalyst ,and hydrophilic. The most popular materials used as GDL in PEMFC are carbon fiber paper and carbon cloth.

5.2.4 Bipolar Flow Plates & Gaskets

The flow plates, used on the cathode and anode side of a PEMFC, distribute fuel and oxidant to reactive sites, collect produced current, remove reaction products and heat, facilitate water management through the cell and provide mechanical support for the cells in a PEMFC stack.

The material and design of the flow plates play a major role in the performance of the PEMFC. The flow channels are machined or pressed into the graphite plates. Graphite is preferred for its high conductivity and low cost. This is the same material used for the gas flow field plates.

Each flow field plate includes a serpentine gas channel to optimize gas contact with the MEA. A consistent gas channel geometry ensures cell stability and product water management. Various designs for the flow field are available including pins, straight channels, serpentine channels, integrated channels, interdigitated channels, and bioinspired flow fields.



Figure 19. PEM Flow Field Plates

Metallic-based bipolar flow plates (SS or Titanium alloys) exhibit several advantages over graphite-based ones including higher strength, lower manufacturing cost, and better electrical conductivity. The major drawback of the metal-based flow plates is the tendency to corrode in the PEM fuel cell environment.

Gaskets must be added around the edges of the MEA to achieve a gas-tight seal. These gaskets are usually made of a rubbery polymer.

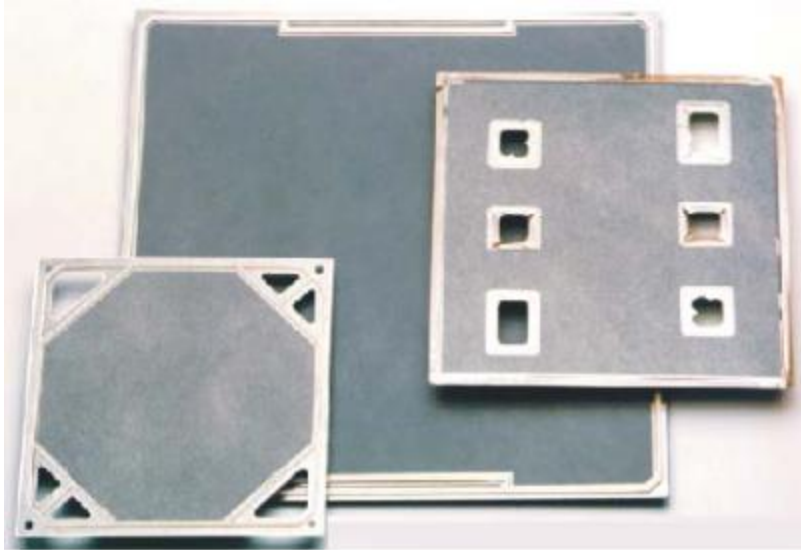

Figure 20. PEM Membrane Electrode Assemblies

5.2.1 Humidifiers

In PEM fuel cells, the reactant gases must be humidified because ion conduction cannot occur without humidification.

To achieve maximum water saturation of the reactant gases, humidification must occur at or near the working temperature of the fuel cell (as set by the stack coolant temperature).

Some fuel cell stacks feature inside humidifiers, while others have external humidifiers.

5.3 Factors Affecting the Performance of Hydrogen Fuel Cell

The performance of the PEM fuel cell can be described by a characteristic curve which plots the voltage output as a function of electrical current density, called as (I-V) curve, as shown in Figure below.

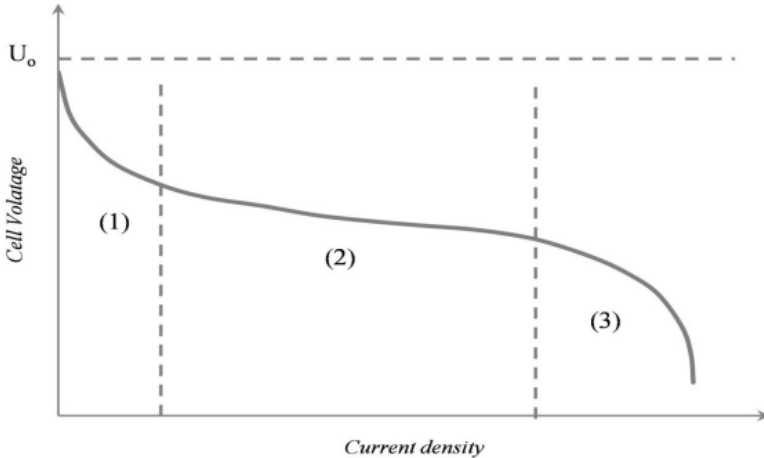

Figure 21. Typical I-V Curve for PEM Fuel Cell

The ideal voltage- current curve is a straight line at 1.23 volts. However, this is not the case for the practical fuel cells which have many types of losses. These losses can be categorized into three main groups as follow:

- 1) Kinetics losses which are due to the poor electrode kinetics and it can be improved by the characteristics of the electrocatalytic layer
- 2) Ohmic losses which are due to the ohmic resistance of the cell components.
- 3) And finally, mass transport losses which are because the water generated from the reaction blocks the channels and lead to the limited diffusion of reactant gases.

Although several factors influence PEMFC performance, we will focus on temperature.

Parameters	Effect on the parameters	Remarks
Performance and efficiency	Increases with the increase in temperature	The PEMFC shows better performance with the rise in temperature and pressure. Because the entropy change is small during the rise in temperature and pressure, it results in better and stable performance in a fuel cell. As the thermal energy is improved, the overall performance like current, current density,

		voltage, electricity production of a proton exchange membrane fuel cell improves.
Humidity	Optimum temperature maintains the required humidity	The proton exchange quality of the membrane depends on the humid condition of the membrane. The presence of water in the membrane maintains the optimum humid condition. Adequate water is required for the membrane to be hydrated and the rest of the water needs to come out of the fuel cell for better performance.
Power Production	Increases with the increase in temperature	The density of power production rises by 16% for the operational temperature rise from 50°C to 80°C.
Voltage	Increases with the increase in temperature	According to the Nernst equation, the temperature is proportional to the output voltage. Higher temperature leads to faster kinetics and as a result, the voltage is also increased.
Leakage Current	Increases with the increase in temperature	The membrane of PEMFC is regarded as hydrogen impermeable and electrically insulated. But leakage current still occurs within the fuel cell. It is often supposed to be around 0.01 A.cm ⁻² in PEM fuel cell simulation literature.

Catalyst Tolerance	Increases with the increase in temperature	The efficiency of catalyst decay over time depends on the hydrogen oxidation reaction, oxygen reduction reaction, high potential, and pH environment. Platinum catalyst plays a vital role in the performance of fuel cells. The oxygen reduction reaction in the cathode is a slow reaction process. To overcome the slowness, an effective catalyst can accelerate the oxygen reaction rate in the cathode which will improve the PEMFC efficiency rapidly.
Mass cross-over	Decreases with the increase in temperature	If the temperature rises, the mass cross-over falls and concentration over-potential rises. The current density becomes high. On the other hand, the activation over-potential remains static up to the 80°C. Then towards 100°C, the activation over-potential rises. It is considered that up to 80°C, the PEMFC efficiency remains in good condition.
Durability	Decreases with the increase in temperature	The durability of the catalyst, electrode plate, gas diffusion layer, the gasket is directly related to the longevity of the proton exchange membrane. Electrochemical erosion, component erosion, and thermal effect are the leading factors for the longevity of the proton exchange membrane.

Table 2. Effect of Temperature on Parameters

5.4 PEMFC Advantages and Disadvantages

5.4.1 Advantages

- a. Have high voltage, current and power density
- b. Operate at low pressure which ensures safety
- c. Operate at low temperatures around 70 -90°C enabling use of low-cost carbon materials.
- d. Quick startup and rapid response.
- e. Have good tolerance to differential reactant gas pressures
- f. Are compact and rugged
- g. Have relatively simple mechanical design

5.4.2 Disadvantages

The disadvantages are that they:

- a. Use an expensive platinum catalyst
- b. Can tolerate only a few ppm of total sulfur compounds
- c. Reactant gas humidification is necessary which adds to system complexity.
- d. PEM fuel cell catalyst is susceptible to CO poisoning due to their low operating temperature. Can tolerate only about 50 ppm carbon monoxide. If the reformat from hydrocarbons or alcohols is utilized as a fuel, the CO concentration must be decreased to 10 ppm.
- e. Membrane electrolyte water management is crucial for cell performance.

5.4.3 Challenges

PEM fuel cell technology faces serious challenges in terms of cost, durability, and performance.

Platinum is used as a catalyst in PEM fuel cells, which is a high-cost component, and it contributes significantly to the overall costs.

Mechanical durability is an important performance aspect for fuel cell power sources, especially in transportation. The mechanical durability of the fuel cell can be enhanced through the design and develop a bipolar plate with high mechanical strength and high corrosion resistance. Metals-based flow plates provide several advantages over the traditional graphite flow plates from the durability point of view. The main drawback of the metallic flow plates is that they normally corrode in the PEM fuel cell environment.

In addition to flow plate corrosion, long-term PEM fuel cell operation causes membrane degradation. The high cost and low durability of the PEM fuel cell are the main commercialization barriers of this technology.

Understanding the materials utilized to manufacture the PEM fuel cell's key components and their present state of development may help immediately solve difficulties connected to the technology's main challenges (high cost and low durability), allowing for global commercialization.

5.4.4 Applications

The main application for PEM fuel cells is transportation, although they can also be used for stationary and portable power generators, and electronic devices. Because of its low-temperature operation, high-power density, fast start-up, system robustness, and reduced sealing, corrosion, shielding, or leaking concerns, it is also a potential candidate for small scale localized power generation, backup power applications such as communication towers and military equipment and can be implemented with a renewable energy system for energy storage application.

A PEM fuel cell can be manufactured as a single cell for low power requirements or as a cell stack with numerous cells coupled to generate the desired voltage and power output.

6 CHAPTER – 6: PHOSPHORIC ACID FUEL CELL (PAFC)

The Phosphoric Acid Fuel Cell (PAFC) is the most mature fuel cell technology in terms of system development and commercialization. It uses phosphoric acid (H_3PO_4) electrolyte in a Teflon® bonded silicon carbide matrix. Some acid fuel cells use a sulfuric acid electrolyte.

6.1 Characteristics

PAFCs have the following characteristics:

- PAFC function at 150-220°C and 15 psig (1 barg). Each cell can produce 1.1 VDC.
- The operation life exceeds 65000 hours.
- The overall cell efficiency is up to 40% which can be boosted up to 60% using CHP.
- Because the cells operate at high temperatures, pure hydrogen is not required as a fuel. This permits the cell to run on somewhat impure hydrogen from the fuel reforming process.

6.2 PAFC Structure

The fundamental cell structure is a ceramic matrix filled with phosphoric acid solution, surrounded by porous electrodes for collecting ions and diffusing gases.

The phosphoric acid-containing ceramic matrix is composed of 1 mm silicon carbide particles, with a matrix thickness of 0.1-0.2 mm. The porous structure of the matrix keeps the acid within the layer and prevents gas cross-over from anode to cathode.

The operating temperature is around 150-220°C. The operating temperature requires platinum catalyst although at this temperature range it is sensitive to CO-poisoning.

The figure below is a depiction of a PAFC.

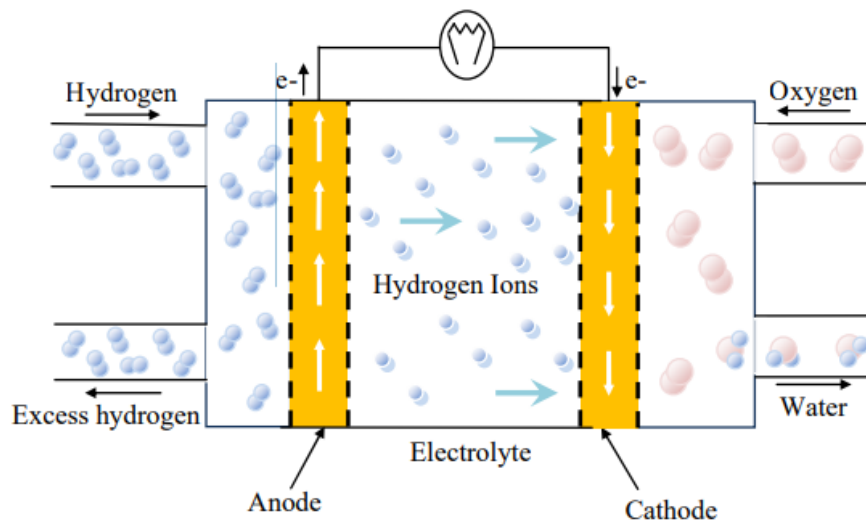

Figure 22. PAFC Structure

The oxygen needed for the cathode of the fuel cell is simply taken from the air. The hydrogen required for the anode must be extracted from liquid natural gas or methanol. This process is called reformation.

The purified hydrogen is fed into the anode of the fuel cell. This fuel is fed through parallel grooves formed of carbon composite plates. These plates are electrically conductive and conduct electrons from the anode to the cathode of the adjacent cell. The design requires the plates to be “bi-polar” which means that one side supplies fuel to the anode, while the other side supplies air or oxygen to the cathode. All the hydrogen in the anode exhaust is not consumed in the fuel cell. The remaining anode exhaust is fed back into the reformer burner, which burns the remaining hydrogen and maintains the high temperature required for the reforming process. Also, water (steam) is recovered from the cathode exhaust to maintain the necessary water supply to the reformer. The water recovery procedure requires that the system be operated at temperatures around 190°C. If the water is not removed, it will dissolve in the phosphoric acid electrolyte and decompose the acid.

Phosphoric acid is employed as the electrolyte because it is the only inorganic acid that has the required thermal, chemical, and electrochemical stability. Carbon monoxide poisoning and carbonate formation is not a problem for PAFCs since phosphoric acid requires high operating temperatures and does not react with CO₂.

6.2.1 Reactions

Anode reaction: $\text{H}_2 \rightarrow 2\text{H}^+ + 2\text{e}^-$

Cathode reaction: $\frac{1}{2}\text{O}_2 + 2\text{H}^+ + 2\text{e}^- \rightarrow \text{H}_2\text{O}$

Overall reaction: $\text{H}_2 + \frac{1}{2}\text{O}_2 \rightarrow \text{H}_2\text{O}$

6.3 Advantages and Disadvantages

6.3.1 Advantages

- a. Simple construction, low electrolyte volatility, and long-term working stability.
- b. Are tolerant of carbon dioxide (up to 30%). So phosphoric acid fuel cells can use clean air as an oxidant and reformat as fuel.

6.3.2 Disadvantages

- a. Can tolerate only about 50 ppm of total sulfur compounds
- b. Use a corrosive liquid electrolyte causing material corrosion problems
- c. Heated steam generated by PAFCs is too low in temperature to be used inside big, combined heat and power (CHP) systems.
- d. Have a liquid electrolyte, introducing liquid handling problems. The electrolyte slowly evaporates over time
- e. Allow product water to enter and dilute the electrolyte
- f. Are big and heavy
- g. Cannot auto-reform hydrocarbon fuels
- h. Must be warmed up before they are operated or be continuously maintained at their operating temperature

6.3.3 Applications

The operative temperature of the PAFCs is too low to be successfully used inside big stationary power generating applications. But these are useful in small, distributed power generation.

7 CHAPTER - 7: MOLTEN CARBONATE FUEL CELLS (MCFC)

In the molten carbonate fuel cell (MCFC), the electrolyte consists of a molten mixture of potassium carbonate and lithium carbonate to transport carbonate ions from the cathode to the anode. The CO_3^{2-} transport needs a supply of CO_2 at the cathode side of the cell which is generally obtained by recycling the anode offside gas. The operating temperature is about 650°C which allows nickel to be used as catalyst material.

The basic principle of the MCFC is shown in the figure below.

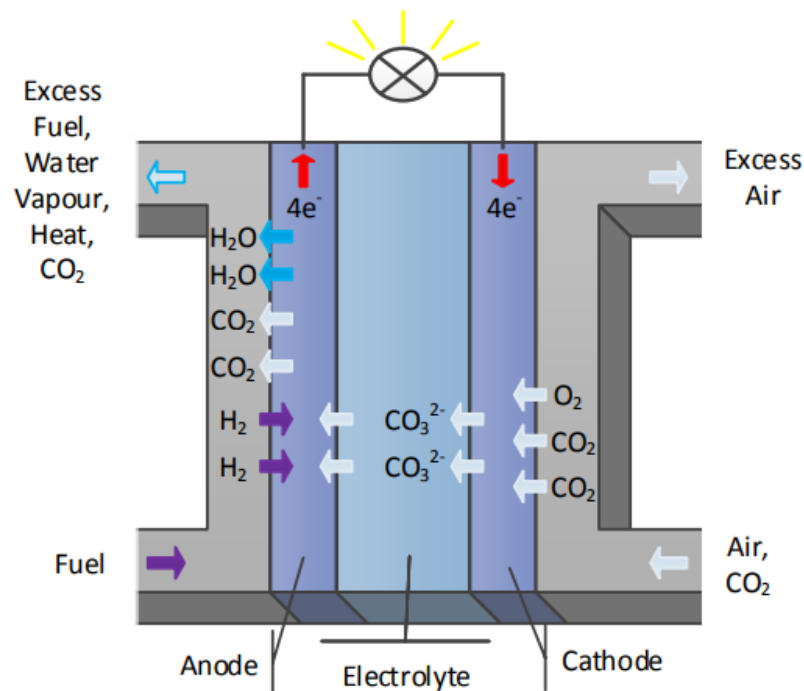

Figure 23. Basic Principle of MCFCs

Ionic salt releases carbonate ions when heated. These flow to the anode and react with hydrogen to generate CO_2 , H_2O , and electrons. Oxygen and CO_2 recycled from the anode react with electrons flowing from the anode through the external circuit, giving back the carbonate ion to the electrolyte.

The cell requires time to start since it needs to reach a temperature of 650°C. Upon reaching this temperature, the carbonate salts begin to melt and become conductive by carbonate ions (CO₃²⁻). These ions are transported from the cathode to the anode where they combine with hydrogen to produce water, carbon dioxide, and electrons. These electrons are then collected by the anode and routed, through an external circuit, to the cathode thus generating electricity and heat.

Their high temperature makes them suitable for cogeneration. With the effective use of waste heat, their efficiency can be enhanced to 60-70 percent by properly utilizing waste heat. Each cell can generate 0.7-1.0 volts DC.

MCFCs can run on methane, natural gas, or coal reforming gases and has good tolerance for impurities in the fuel. MCFCs can convert fuels directly into hydrogen without external reformers. In fact, due to the high temperatures, the fuels can be directly converted to hydrogen through a process called catalytic internal reforming which take places in a pre-chamber inside the anode compartment. The main problem of this configuration is the coarseness of the reforming catalyst, which reduces the lifetime of the system.

7.1.1 Reactions

Anode reaction: $H_2 + CO_3^{2-} \rightarrow CO_2 + H_2O + 2e^-$

Cathode reaction: $\frac{1}{2}O_2 + CO_2 + 2e^- \rightarrow CO_3^{2-}$

Overall reaction: $H_2 + \frac{1}{2}O_2 \rightarrow H_2O$

7.2 Structure of MCFC

The base construction of an MCFC is a ceramic matrix containing the electrolyte which is surrounded by the anode, fueled by hydrogen-rich fuel, and the cathode, fueled by oxygen (usually air).

There are two mixes of molten carbonate salts - a combination of lithium carbonate and potassium carbonate or lithium carbonate and sodium carbonate. Those electrolytes are dispersed inside a porous and chemically inert ceramic matrix made with lithium aluminate (LiAlO₂). Inside this structure, ceramic powder and fibers are used to reinforce the total mechanical strength.

Because of the high operating temperature, a comparatively cheap catalyst like nickel can be utilized instead of the considerably expensive ones like platinum. The anode is a porous electrode produced using a nickel alloy (Ni-5Cr, Ni-xAl) as the catalyst. These alloys contain a little amount of aluminum or chromium to suppress the hot creep inside the electrode structure. The cathode is realized with a porous nickel catalyst.

7.3 Advantages and Disadvantages

7.3.1 Advantages

- a. Molten carbonate fuel cells can run on natural gas or coal gasified gasses. This eliminates the requirement for on-site hydrogen storage or an external reformer.
- b. Can reach up to 50% efficiency and provide high-quality heat, making them suitable for cogeneration. The total heat and power efficiency of MCFC applications is 60–70%.
- c. No noble metal catalyst is required. This reduces the cost of cell-building by using conventional materials like stainless steel and nickel-based alloys.

7.3.2 Disadvantages

- a. Corrosion can dissolve nickel oxide from the cathode into the electrolyte. This can lead to electrolyte loss, deterioration of separator plates, probable cell short-circuits, dehydration or flooding of electrodes, decreased performance, reduced cell life, and cell failure. Using a platinum catalyst solves some of these issues but eliminates the cost-saving benefit.
- b. Susceptible to dimensional instability, which can distort electrodes, reduce active surface area, and induce contact loss and excessive component resistance.
- c. Intolerance to sulfur. The anode can only withstand 1-5 ppm sulfur compounds (mostly H₂S) in the fuel gas without performance degradation.
- d. Use a liquid electrolyte, which introduces liquid handling issues.
- e. Take considerable time to warm up.

7.3.3 Challenges

The molten carbonate cells are likely to occupy the same market segment as the SOFCs. The primary difference is that MCFCs require CO₂ recirculation, implying that it is difficult to design a power system below 250kW. This removes the market in domestic scale power.

7.3.4 Applications

Molten carbonate fuel cells operate at higher temperatures and are also designed to be used as a baseload, 24/7 power source.

Because of their high working temperature, MCFC is used in stationary power production and CHP applications. They can produce high powers up to 100 MW.

They are not so expensive in production and hence can be used for commercial uses.

8 CHAPTER - 8: SOLID OXIDE FUEL CELLS (SOFC)

Solid Oxide Fuel Cells (SOFCs) uses nonporous metal oxide electrolyte that conducts oxide (O^{2-}) ions from the cathode to the anode. This is unlike most fuel cells, which conduct hydrogen ions from the anode to the cathode.

The electrolyte is a ceramic made of a solid oxide, commonly zirconia (stabilized with other rare earth oxides like yttrium). Its all-solid-state ceramic design provides efficiency, stability, and dependability.

Solid oxide fuel cells operate at about $1000^{\circ}C$ and a pressure of 15 psig (1 barg). Each cell produces 0.8-1.0 VDC.

The SOFC's high interior temperature is both an asset and a liability. The high temperatures allow electrochemical reactions to occur without the usage of noble metal catalysts. Owing to the high temperatures, a wide range of hydrogen-containing fuels (coal gas, biogas, propane, natural gas, hydrogen) can be used. The drawback is that the high temperatures shorten stack life and increase costs.

SOFCs have a thermal and power efficiency of 60%. Because of the high-quality waste heat, steam can be generated and used in a CHP system, enhancing efficiency up to 80%.

8.1 Solid Oxide Fuel Cells Structure

SOFCs are classified as oxygen conducting or hydrogen conducting. Since there are no chemically stable hydrogen ion electrolytes yet, research has centered on oxygen ion electrolytes.

The cell's basic construction remains unchanged: the anode and cathode are separated by an electrolyte layer. The electrolyte layer is a thin solid ceramic material such as Yttrium doped zirconium oxide (YSZ) which has good ionic conductivity, chemical stability, and mechanical strength.

The cathode is porous to allow oxygen gas to pass between it and the electrolyte. Due to the high temperatures involved, most construction materials are strontium doped $LaMnO_3$.

The anode is porous nickel yttrium doped zirconium oxide (Nickel-YSZ). Nickel functions as an oxidation catalyst but has issues like high thermal expansion and microstructure coarsening. YSZ limits these characteristics and enhances anode-electrolyte interface adhesion.

The cell works by supplying air to the cathode where the oxygen molecules are split into oxygen ions (O^{2-}) with the addition of four electrons. The ions go through the electrolyte to the anode, where they recombine with the supplied hydrogen, releasing additional electrons and producing hot water. The anode collects the electrons and generates the current.

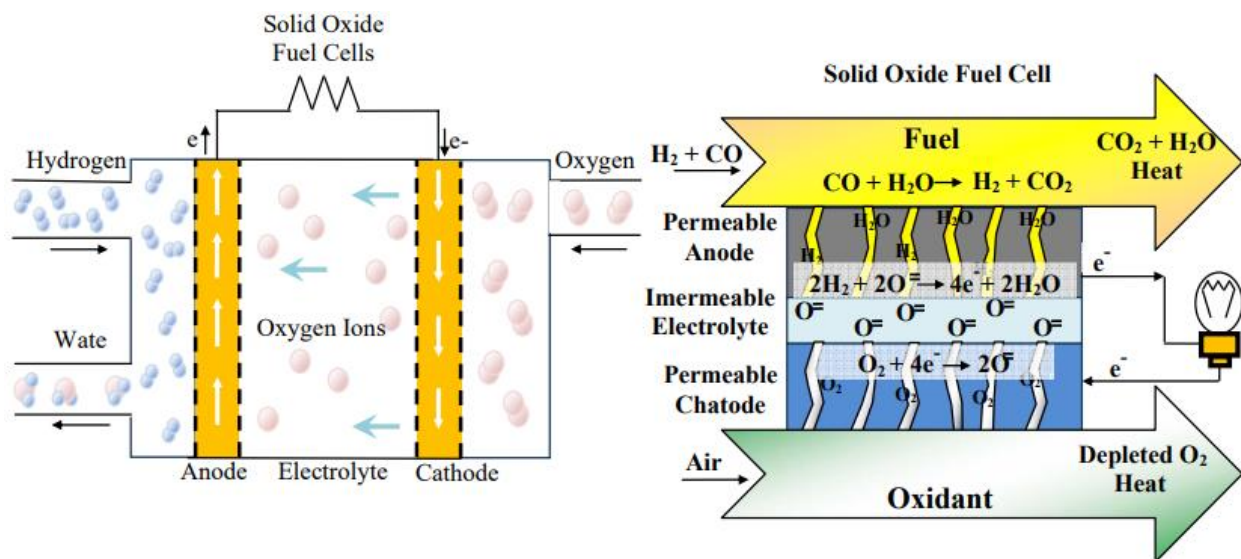

Figure 24.SOFC Structure

8.2 Design Configurations

There are two major configurations for the solid oxide fuel cell: tubular and planar. Although the tubular configuration is more developed than the planar configuration, there has been increasing research being done on the later.

8.2.1 Tubular

The tubular SOFC design constructs the cell stack as a bundle of tubular electrode- electrolyte assemblies connected in series. The air is introduced to the interiors of the individual tubes while the fuel passes through the exteriors of the tubes to produce electricity. The major advantage to

this design is that it alleviates the problem of using high-temperature seals. Various studies have also shown that the stacks of tubular design have been operated over 100,000 hours and have shown little or no cell degradation. However, the long current path from the cell to the interconnect limits the performance of the cell. Examples of companies that make this design are Siemens Westinghouse Power Corporation and a few Japanese companies such as Mitsubishi Heavy Industries.

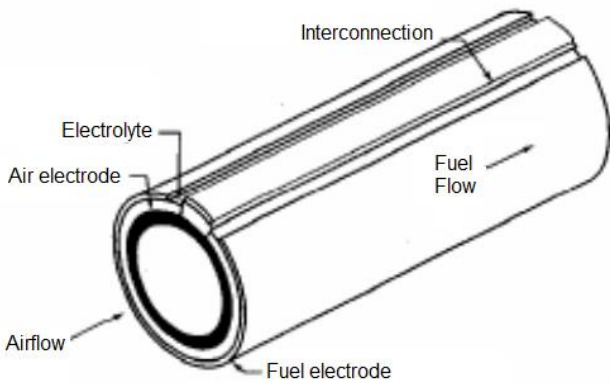

Figure 25. Cross-section of the Tubular Design

8.2.2 Planar

The planar (also known as flat plate) design is common for other fuel cell stacks such as PAFCs. The flat plates are bonded together in series to form electrode-electrolyte layers, unlike the tubular design. The overall stack performance is improved since there is lower ohmic resistance and higher power densities. The planar design is easier to manufacture and is about 25% cheaper to make. The only disadvantage to this design is that high-temperature seals are necessary. Examples of companies that use this concept are Ceramatec, Inc., General Electric, SOFCo, and AlliedSignal. The figure below is an illustration of the planar SOFC design.

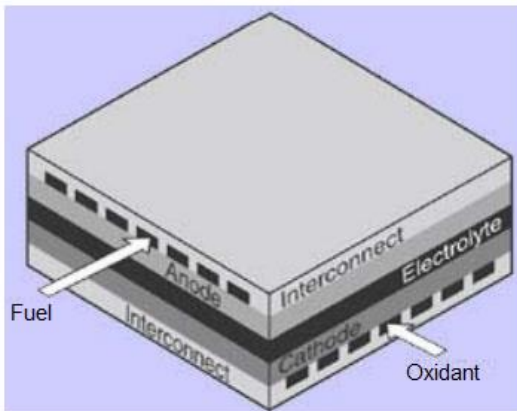

Figure 26. Planar Cell Design

8.3 Advantages and Disadvantages

8.3.1 Advantages

- a. They are not poisoned by carbon monoxide (CO); they are also sulfur resistant.
- b. The high operating temperatures support effective fuel processing (internal reforming), therefore producing high-quality byproduct heat for cogeneration uses and efficiencies up to 85%.
- c. They do not require expensive catalysts.
- d. There is less restriction on the cell's configuration because of its solid-state character. The cell can be produced in a variety of self-supporting shapes and configurations.
- e. Due to an all-solid-state ceramic construction, it offers stability and reliability.
- f. They can operate on a range of low-cost hydrocarbon fuels (biogas, coal gas, natural gas).
- g. They operate at higher current densities than molten carbonate fuel cells
- h. Have a solid electrolyte, avoiding problems associated with handling liquids.

8.3.2 Disadvantages

- a. There are strict restrictions on the raw materials due to the high operating temperature of 1,000°C. Only a few materials can operate at high temperatures and remain solid. To avoid delamination and cracking during heat cycles, the materials must be dense enough to

prevent fuel and oxidant gas mixing and have closely matched thermal expansion characteristics. SOFC construction requires the development of materials with the appropriate conductivity, chemical compatibility with other cell components, dimensional stability, durability, and high endurance.

- b. SOFC in general are more tolerant to sulfur compounds than are MCFCs, although overall levels must still be limited to 50 ppm. This higher sulfur tolerance makes these fuel cells attractive for heavier fuels. Excess sulfur in the fuel affects performance.
- c. Suffer from a considerably long starting time.

8.3.3 Challenges

A fundamental problem with SOFC systems is to overcome heat loss. The higher the heat loss the more recuperation is necessary to maintain the fuel cell within an acceptable temperature range, and hence to assure good performance.

8.3.4 Applications

SOFCs operate at high temperatures, making them ideal for applications that require high-temperature heat. This heat can be used in two ways: to heat industrial or residential operations, or to power turbines for additional electricity production.

This device is also unique in that it can use a variety of fuels. Most of the petroleum products can be used as fuel.

9 CHAPTER - 9: DIRECT METHANOL FUEL CELLS (DMFCS)

Direct Methanol Fuel Cells (DMFC) has somewhat the same qualities as that of a PEMFC, however, the distinction is that it uses methanol directly as a fuel. It simplifies the fuel storage system and eliminates the need to produce hydrogen.

However, the drawbacks are the lower electrochemical activity of the methanol as compared to hydrogen, giving rise to lower cell voltages and, hence, efficiencies. Also, methanol is miscible in water, so some of it is liable to cross the water-saturated membrane and cause corrosion and exhaust gas problems on the cathode side.

These cells work between 70°C and 100°C. The efficiency is typically <30 percent and needs a significant amount of anode catalyst and therefore highly expensive.

Individual fuel cells have a maximum output voltage of the order of 1-volt DC. Substantial voltages and power outputs are obtained by connecting many cells electrically in series to form a fuel cell stack.

9.1 DMFC Structure

The core of DMFC comprises an anode, cathode, electrolyte, and catalyst sandwiched between two graphite flow field plates. The plates channel the fuel and air to opposite sides of the membrane electrode assembly (MEA). The cooling plates convey the coolant past the fuel cells to absorb heat and regulate the reaction temperature. Seals between the graphite plates ensure that the oxidant, fuel, and coolant streams never mix within the fuel cells.

Electrical endplates are positioned at the flow field plate ends. These endplates connect to the output power terminals from which the output power is extracted.

Practical fuel cell design relies on generating high-power output per area of the membrane, scaling the active membrane area to a workable size, and making the whole stack appropriately compact for its intended use. Seals, flow field pattern tolerances, and cell alignment is critical.

The catalytic layer is composed of a mixture of a catalyst, which is usually a combination of platinum (at the cathode) and platinum-ruthenium alloy (at the anode) nanoparticles and an

ionomer. The main property of the catalytic layer is its mixed conductivity for both protons and electrons.

The diffusion layer is composed of a mixture of carbon and Teflon with hydrophobic properties which allows both the passage of oxygen molecules to the catalyst layer of the cathode and the escape of CO₂ molecules from the anode.

The combination of the membrane and the electrodes gives life to the MEA assembly which thickness is usually around 1 millimeter.

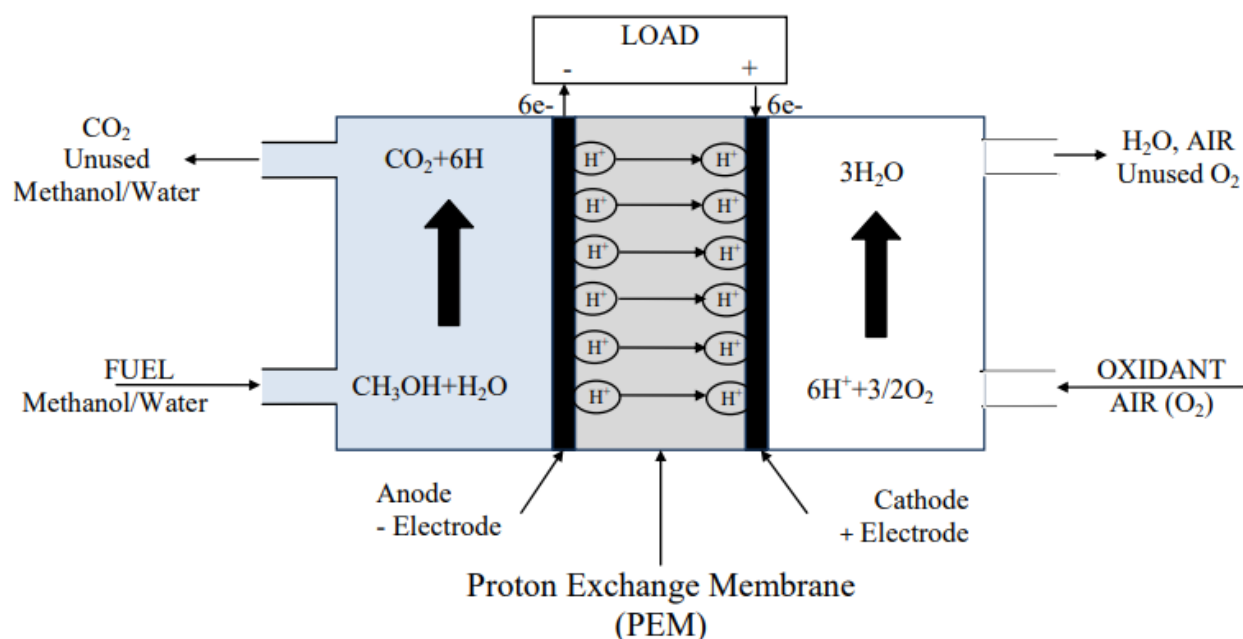
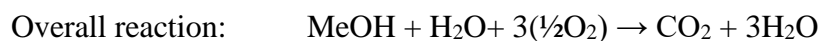
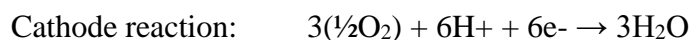

Figure 27. DMFC Structure

9.1.1 Reactions



9.2 Advantages and Disadvantages

9.2.1 Advantages

The main advantage of DMFC is the fuel used, which is Methanol. Because methanol is cheap and easy to produce fuel, it may be directly pumped into the cell, allowing for a simpler cell structure and lighter weight.

Like PEMFCs, DMFCs are considered green technology since they produce no sulfur or nitrogen emissions (only carbon dioxide).

9.2.2 Disadvantages

DMFCs have the lowest efficiency of all fuel cells at roughly 30%.

The power density is low at 200-400 mW/cm². They can't handle the energy needs of many portable applications.

This technology is still in its infancy, although increasing interest in low-power portable applications has considerably increased development efforts. These efforts focus on:

- a. Increasing methanol reactivity by developing novel catalysts.
- b. The use of higher temperatures and improved membranes to avoid methanol cross-over.
- c. The optimization of the electrodes and the MEA assembly.

9.2.3 Applications

DMFC is considered a popular technology for portable applications and generators. The two main commercial applications are:

- a. Portable power generation
- b. Low weight substitute of the batteries for both civil and military environments.

10 CHAPTER - 10: ALKALINE FUEL CELLS (AFC)

Alkaline Fuel Cells (AFCs) uses a solution of potassium hydroxide electrolyte that conducts hydroxyl (OH^-) ions from the cathode to the anode. This is unlike many other types of fuel cells that conduct hydrogen ions from the anode to the cathode.

AFC uses hydrogen as fuel and pure oxygen (NOT AIR) as an oxidant because CO_2 in the air carbonates the electrolyte (350 ppm).

10.1 Type of Electrolytes

The electrolyte can be mobile, static, or dissolved fuel type.

10.1.1 Mobile Alkaline Electrolyte

Mobile alkaline electrolyte fuel cells circulate an electrolyte between the electrodes. Since it tends to evaporate the water product and consequent dilution of the electrolyte, the water is extracted with the help of a condenser. The major challenge is the chemical reaction between the potassium hydroxide (KOH) and the carbon dioxide (CO_2) that is present in the air. This reaction is undesirable because the effectiveness of the fuel cell depends upon the purity of the potassium hydroxide solution. To tackle this problem a carbon dioxide scrubber (very expensive) is employed to preserve the solution as pure as possible. This type of design is the one that was used inside the Apollo space shuttle, where the cost was not a problem.

10.1.2 Static Alkaline Fuel Cells

Static Alkaline fuel cells use a thick paste of electrolyte kept together by capillary forces within a porous matrix, preventing electrolyte circulation. The paste itself provides gas sealing. Product water evaporates into the source hydrogen gas stream at the anode from which it is subsequently condensed. A circulating coolant removes the waste heat. This AFC variant requires pure oxygen infusion into the cathode. A cooling system keeps the fuel cell within the required operating temperature range.

10.1.3 Dissolved Fuel Type AFC

Dissolved fuel type AFC is the easiest to realize. Like the others, this design uses potassium hydroxide, but the electrolyte is mixed with hydrazine or ammonia. This type of AFC, which is

not suitable for large power generators, has issues with the fuel crossover but can be overlooked because the catalyst used is not platinum (thus greatly reducing the costs for the substitution of the catalyst). The main issue is the type of fuel. The most suitable fuel for this cell is hydrazine (due to its capacity to split into hydrogen and nitrogen) which is a toxic, carcinogenic, and explosive fuel.

AFCs operate at about 65 to 220°C and have a pressure of about 15 psig (1 barg). Each cell can produce a voltage between 0.5- and 0.9-volts DC depending on the design with an efficiency up to 65%.

10.2 Alkaline Fuel Cells Structure

An AFC has a porous anode and a porous cathode, separated by a liquid KOH electrolyte.

The fuel electrode is made of palladium plus silver, and the fuel is either alcohol or a hydrocarbon which is reformed with steam on a nickel catalyst on one side of the electrode. The hydrogen formed passes through the electrode and reacts with the electrolyte, but the palladium prevents the CO₂ to pass through and get into the electrolyte.

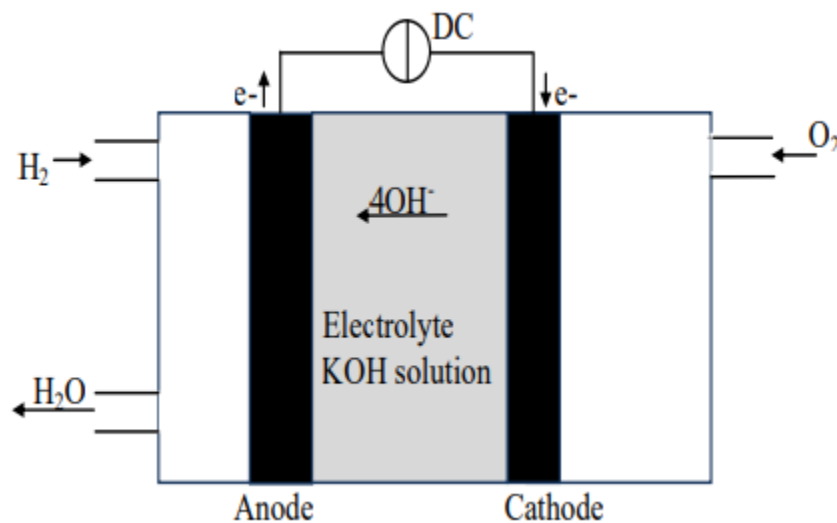

Figure 28. AFC Structure

10.2.1 Reactions

Anode reaction: $\text{H}_2 + 2\text{OH}^- \rightarrow 2\text{H}_2\text{O} + 2\text{e}^-$

Cathode reaction: $\frac{1}{2}\text{O}_2 + \text{H}_2\text{O} + 2\text{e}^- \rightarrow 2\text{OH}^-$

Overall reaction: $\text{H}_2 + \frac{1}{2}\text{O}_2 \rightarrow \text{H}_2\text{O}$

10.3 Advantages and Disadvantages

10.3.1 Advantages

The advantages of alkaline fuel cells include:

- a. Low-temperature cells have the advantage of being able to start up easily from cold
- b. Competitive costs due to the simplicity of the materials used in cell structure
- c. High efficiency up to 65% (which is high for cold fuel cells).
- d. Need little or no platinum catalyst
- e. Minimal corrosion
- f. The relative ease of operation
- g. Low mass and volume

10.3.2 Disadvantages

Disadvantages include:

- a. The intolerance of this type of cell to carbon dioxide (maximum 350 ppm) is a major problem. A small amount of CO_2 can significantly reduce cell efficiency because of the strong reactivity of OH^- ions with carbon and its composites.
- b. The oxidant must be pure oxygen and the fuel must be pure hydrogen. Very expensive purification systems are required to guarantee the gases purity thus greatly increasing the effective cost of a power generator based on AFCs.
- c. A liquid electrolyte causes complications with liquid handling.
- d. Require complex water management
- e. Have a short lifespan of about 10,000-15,000 hours (however life cycles of 40,000 hours are required for a full commercialization of a fuel cell technology).

AFCs are cheaper and more efficient than PEM fuel cells. The reason which prohibits the AFCs to become the dominant fuel cell technology is the CO_2 poisoning of the electrolyte and low cycle life.

10.3.3 Applications

The AFC has a long history in space programs, primarily because it was the first fuel cell to be sufficiently developed. It is still used in the space shuttle in a very expensive guise, producing power for the on-board systems by combining the pure hydrogen and oxygen stored in the rocket-fueling system, and producing water for the astronauts to drink.

11 CHAPTER -11: SUMMARY COMPARISON OF FUEL CELLS

11.1 Characteristics of Different Fuel Cells

Fuel Cell Type	Common Electrolyte	Temperature Range	System Output	Electrical Efficiency
Polymer Electrolyte Membrane (PEM)	Solid organic polymer poly-perfluorosulfonic acid	50 - 100°C	<1kW – 250kW	53 -58% (vehicles) 25-35% (stationary)
Direct Methanol (DMFC)	Solid organic polymer poly-perfluorosulfonic acid	60 - 90°C	Up to 1.5kW	20 - 25%
Alkaline (AFC)	Aqueous solution of potassium hydroxide soaked in a matrix	90 - 100°C	10kW – 100kW	60%
Phosphoric Acid (PAFC)	Liquid phosphoric acid soaked in a matrix	150 - 200°C	50kW – 1MW (250kW module typical)	32-38%
Molten Carbonate (MCFC)	Liquid solution of lithium, sodium, and/or potassium carbonates soaked in a matrix	600 - 700°C	<1kW – 1MW (250kW module typical)	45-47%

Solid Oxide (SOFC)	Solid zirconium oxide to which a small amount of Yttria is added	650 - 1000°C	5kW – 3MW	35-43%
--------------------	--	--------------	-----------	--------

Table 3. Characteristics of Different Fuel Cells

Source: US DOE Energy Efficiency and Renewable Energy (EERE), August 2007

11.1.1 Advantages and Disadvantages

Fuel Cell Type	Advantages	Disadvantages
Polymer Electrolyte Membrane (PEM)	Solid electrolyte reduces corrosion & electrolyte management problems Low temperature Quick start-up	Requires expensive catalysts High sensitivity to fuel impurities Low temperature waste heat Waste heat temperature not suitable for combined heat and power (CHP)
Direct Methanol (DMFC)	High energy storage No reforming needed Easy storage and transport	Low power output Methanol is toxic and flammable
Alkaline (AFC)	Cathode reaction faster in alkaline electrolyte, higher performance	Expensive removal of CO ₂ from fuel and air streams required (CO ₂ degrades the electrolyte)
Phosphoric Acid (PAFC)	Higher overall efficiency with CHP Increased tolerance to impurities in hydrogen	Requires expensive platinum catalysts Low current and power Large size/weight

Molten Carbonate (MCFC)	High efficiency Fuel flexibility Can use a variety of catalysts Suitable for CHP	High temperature speeds corrosion and breakdown of cell components Complex electrolyte management Slow start-up
Solid Oxide (SOFC)	High efficiency Fuel flexibility Can use a variety of catalysts Solid electrolyte reduces electrolyte management problems Suitable for CHP Hybrid/GT cycle	High temperature enhances corrosion and breakdown of cell components Slow start-up Brittleness of ceramic electrolyte with thermal cycling

Table 4. Advantages and Disadvantages of Different Fuel Cell Types

Source: Mostly US DOE Energy Efficiency and Renewable Energy (EERE), August 2007

11.1.2 Applications

Fuel Cell Type	Applications
Polymer Electrolyte Membrane (PEM)	Backup power Portable power Small distributed generation Transportation
Direct Methanol (DMFC)	Consumer goods Laptops Mobile phones Portable power

	Military devices
Alkaline (AFC)	Military Defense Space
Phosphoric Acid (PAFC)	Distributed generation
Molten Carbonate (MCFC)	Electric utility Large distributed generation
Solid Oxide (SOFC)	Auxiliary power Electric utility Large distributed generation

Table 5. Different Fuel Cells Applications

Source Mostly US DOE Energy Efficiency and Renewable Energy (EERE), August 2007

Different types of fuel cell are suitable for different applications according their capacity, materials, and operating conditions. Figure below illustrates the compatibility of different fuel cell types with different applications.

Types of Applications	Portable electronics Equipment	Cars, boats, and domestic CHP	Distributed power generation, CHP
Power (W)	1 10 100	1k 10k	100k 1M 10M
Main Advantages FCs Bring to Application	Higher energy density than batteries, Faster recharging	Potential for zero emissions, Higher efficiency	Higher efficiency, low noise, low pollution
Different types of FCs that can be employed for the application			

Figure 29. Fuel Cell Types for Different Applications

11.2 Key Suppliers

The table below includes a few industry leaders, though it is by no means comprehensive.

Fuel Cell Type	Company	Location
Alkaline Fuel Cells (AFC)	International Fuel Cells	USA
	Zevco	Belgium/UK
Polymer Electrolyte Membrane Fuel Cells (PEMFC)	Advanced Power Sources	UK
	Avista Labs	USA
	Ballard	Canada
	DeNora	Italy
	Energy Partners	USA
	Fuji Electric	Japan

	<p>H Power</p> <p>Mitsubishi Electric</p> <p>Plug Power</p> <p>Siemens</p> <p>Toyota</p> <p>Honeywell, American Fuel Corporation, Northwest Power Systems, DuPont, Johnson Matthey, 3M and GORE</p>	<p>USA</p> <p>Japan</p> <p>USA</p> <p>Germany</p> <p>Japan</p> <p>USA</p>
Phosphoric Acid Fuel Cells (PAFC)	<p>ONSI</p> <p>Toshiba</p>	<p>USA</p> <p>Japan</p>
Molten Carbonate Fuel Cells (MCFC)	<p>Energy Research Corporation</p> <p>MC-Power</p> <p>Motoren und Turbinen Union</p> <p>Ishikawajima-Harima Heavy Industries</p>	<p>USA</p> <p>USA</p> <p>Germany</p> <p>Japan</p>
Solid Oxide Fuel Cells (SOFC)	<p>Allied Signal</p> <p>Ceramic Fuel Cells</p> <p>Mitsubishi Heavy Industries</p> <p>Rolls-Royce</p> <p>Siemens-Westinghouse</p> <p>Sulzer Hexis</p>	<p>USA</p> <p>Australia</p> <p>Japan</p> <p>UK</p> <p>Germany/USA</p> <p>Switzerland</p>

Figure 30. Industry Leaders for Fuel Cells

12 CHAPTER - 12: COST ECONOMICS OF FUEL CELLS

Cost is a crucial factor for the increased commercialization of fuel cells. The total cost of ownership typically includes three components: capital costs of equipment and installation, fuel costs, and O&M costs.

Costs for stationary fuel cell systems vary by type and application. We will compare SOFC and PEFC costs to obtain an understanding.

12.1 Capital Cost

The main component of a fuel cell's first cost is the production costs, which are highly dependent on system configuration, embodiment, and production methods. Manufacturing processes are closely tied to the projected production volume, while system configuration and design directly impact desired system functioning and performance.

Installed costs vary depending on plant equipment, location, market conditions, particular site needs, and current labor rates.

12.1.1 Cost of Low-temperature PEMFC

Stack costs range from \$250/kW to \$600/kW.

12.1.2 Cost of High-temperature PEMFC

Stack costs range from \$600/kW to \$1100/kW.

12.1.3 Cost of SOFC System

Stack costs range from \$350-550/kW

Source: <http://lma.berkeley.edu/>

A typical cost break-up for PEMFC is as below:

Annual Volumes	100	1,000	10,000	50,000
Direct Material	333.31	275.34	223.85	190.30
Labor	32.52	25.06	22.65	22.39
Process: Capital	130.35	28.58	17.24	16.94
Process: Operational	14.60	5.93	4.82	5.25
Process: Building	20.67	2.44	0.77	0.68
Material Scrap	24.67	8.92	3.28	2.65
Total (\$/kWnet)	556.13	346.27	272.60	238.22

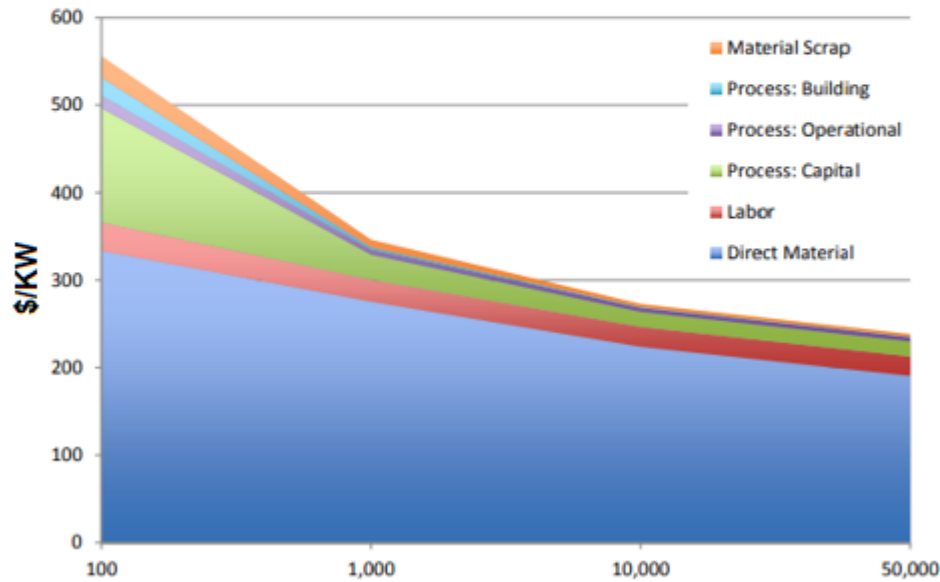

Figure 31. Annual Production

- Direct material cost dominates stack cost for all systems at all production volumes.
- Solid-oxide fuel cell systems are the lowest stack cost.
- Low-temperature PEM fuel cells are a close second.
- High-temperature PEM fuel cells trail far behind.
- Capital cost is large at low production volumes due to low line utilization.
- High-temperature systems tend to be more expensive as they require significant investment in the associated “balance of plant (BOP)” but should still be able to be manufactured for sale close to 600 dollars per kilowatt, not far from the current price for a gas turbine or gas engine.

The main difference in SOFC stack cost compared to PEFC cost relates to the simpler system configuration of the SOFC system. This is mainly because SOFC stacks do not contain the high-cost precious metals that PEFCs contain. This is offset in part by the relatively complex manufacturing process required for the SOFC electrode/electrolyte plates and by the somewhat lower power density in SOFC systems. Low-temperature operation (enabled with electrode-supported planar configuration) enables the use of low-cost metallic interconnects that can be manufactured with conventional metal forming operations.

The BOP contains all the direct stack support systems, reformer, compressors, pumps, and recuperating heat exchangers. Its cost is low in comparison to the PEFC because of the simplicity of the reformer. However, the cost of the recuperating heat exchangers partially offsets that.

12.2 Fuel Costs

The real cost of the energy supplied by fuel cells depends very much on the cost of the Hydrogen it consumes and this, in turn, depends on how the Hydrogen was produced.

Until recently, steam reformation of natural gas was the cheapest way of producing Hydrogen, but production costs have risen with the cost of the fuel. Currently, assuming the cost of natural gas is about \$10 per M Btu (Million Btu) the bulk cost of Hydrogen at the production plant will be about \$5/Kg. The cost of pressurizing the gas and distributing it to refueling stations will add to this amount.

Generating Hydrogen by electrolysis from wind farm electricity is now the cheapest way of producing gas.

Currently, the retail price of pressurized hydrogen from an unsubsidized supplier is about \$100/kg plus cylinder rental.

12.3 Maintenance Costs

Maintenance costs for fuel cell systems will vary with the type of fuel cell, size, and maturity of the equipment. Some of the typical costs that need to be included are:

- a. Maintenance labor.

- b. Ancillary replacement parts and material such as air and fuel filters, reformer igniter or spark plug, water treatment beds, flange gaskets, valves, electronic components, etc., and consumables such as sulfur adsorbent bed catalysts and nitrogen for shutdown purging.
- c. Major overhauls include shift catalyst replacement (3 to 5 years), reformer catalyst replacement (5 years), and stack replacement (5 to 10 years).

Maintenance can either be performed by in-house personnel or contracted out to manufacturers, distributors, or dealers under service contracts. Details of full maintenance contracts (covering all recommended service) and costing are not generally available but are estimated at 0.7 to 2.0 cents/kWh excluding the stack replacement cost sinking fund. Maintenance for initial commercial fuel cells has included remote monitoring of system performance and conditions and an allowance for predictive maintenance. Recommended service is comprised of routine short interval inspections/adjustments and periodic replacement of filters (projected at intervals of 2,000 to 4,000 hours).

Course Summary

Fuel cells are coming into widespread commercial use for stationary power and transportation applications because of their high efficiency, zero noise pollution and low environmental impact.

The fuel cells offer following advantages:

- a. Direct energy conversion (no combustion)
- b. No moving parts in the energy converter
- c. Quiet
- d. Demonstrated high availability of lower temperature units
- e. Siting ability
- f. Fuel flexibility
- g. Demonstrated endurance/reliability of lower temperature units
- h. Good performance at off-design load operation
- i. Modular installations to match load and increase reliability
- j. Remote/unattended operation
- k. Size flexibility
- l. Rapid load following capability

A few drawbacks of fuel cells include:

- a. High costs
- b. Endurance/reliability of higher temperature units not demonstrated
- c. Unfamiliar technology to the power industry
- d. No infrastructure

The major drawback of fuel cell is the high cost of production and operation (\$/kWh). Specific areas where cost reductions are being investigated are:

- a. Material reduction and exploration of lower-cost material alternatives
- b. Reducing the complexity of an integrated system
- c. Minimizing temperature constraints (which add complexity and cost to the system)
- d. Streamlining manufacturing processes

- e. Increasing power density (footprint reduction)
- f. Scaling up production to gain the benefit of economies of scale (volume) through increased market penetration.

References:

- Fuel Cell Handbook by EG&G Technical Services, Inc. for U.S. Department of Energy dated Nov 2004
- Section 6. Technology Characterization – Fuel Cells by Ken Darrow, Rick Tidball, James Wang and Anne Hampson at ICF International, the U.S. Environmental Protection Agency and the U.S. Department of Energy. March 2015
- An introduction to Fuel Cell Technology and Economics by Nigel Brandon and David Hart. Report published by the Centre for Energy Policy and Technology, Imperial College, London July 1999
- Fuel Cells: Technologies and Applications by Leonardo Giorgi and Fabio Leccese. Published by The Open Fuel Cells Journal, 2013
- Economic Aspects of Fuel Cell-Based Stationary Energy Systems by Suat Sevensan, Doctoral Thesis, KTH Royal Institute of Technology, 2016